



**Rewarding Learning**

**General Certificate of Secondary Education  
2020**

Centre Number

--	--	--	--	--

Candidate Number

--	--	--	--

---

## Mathematics

Unit **M6** Paper 2

(With calculator)

Foundation Tier



## PRACTICE PAPER

---

### TIME

1 hour

### INSTRUCTIONS TO CANDIDATES

Write your Centre Number and Candidate Number in the spaces provided at the top of this page.

Write your answers in the spaces provided in the question paper.

Complete in blue or black ink only. **Do not write in pencil or with a gel pen.**

Answer **all fifteen** questions.

Any working should be clearly shown in the spaces provided since marks may be awarded for partially correct solutions.

You can use a calculator for this paper.

### INFORMATION FOR CANDIDATES

The total mark for this paper is 50

Figures in brackets printed down the right-hand side of pages indicate the marks awarded to each question or part question.

Functional Elements will be assessed in this paper.

You should have a ruler, compasses and protractor.

The Formula Sheet is on page 2.

## Formula Sheet

Area of trapezium =  $\frac{1}{2}(a + b)h$

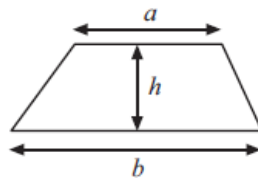

Volume of prism = area of cross section  $\times$  length

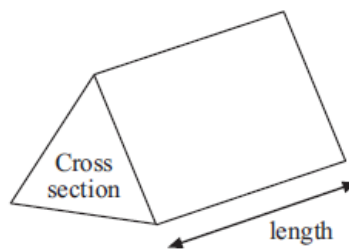

1. Here are some cards.

Each card has 2 numbers on it.

<b>A</b>	<b>B</b>	<b>C</b>	<b>D</b>	<b>E</b>
51	53	57	49	91
47	59	61	64	63

(a) Which card has numbers which are both prime numbers?

Answer \_\_\_\_\_ [1]

(b) Which card has numbers which are both square numbers?

Answer \_\_\_\_\_ [1]

2. Mark is designing a new kitchen.

The kitchen is a rectangle measuring 8m by 6m.

Mark uses the scale 1:50

What size is the kitchen in the scale drawing?

Answer \_\_\_\_\_ cm by \_\_\_\_\_ cm [2]

3. Sam owned 120 sheep.

He sold 30% of them.

He split the remainder of them between 2 fields in the ratio 3:4

How many sheep were in each field?

Answer \_\_\_\_\_ and \_\_\_\_\_ [3]

4. A photograph measures 15 cm by 10.5 cm.

It is enlarged and now measures 45 cm by 31.5 cm.

How many times bigger is the area of the new photograph?

Answer \_\_\_\_\_ [2]

5. The cooking instructions for a turkey are

‘Cook for 20 minutes per 1 lb for the first 4 lb, then 25 minutes for every  
1 lb over that weight’

Janice has bought a 5 kg turkey.

How long, in total, should she cook her turkey?

Answer \_\_\_\_\_ [5]

6. A 100 ml bottle of aftershave costs £85

An 80 ml bottle of the same aftershave costs £70

On Saturday morning there is 20% off the cost of the 100 ml bottle and 25% off the cost of the 80 ml bottle.

Which bottle is better value on the Saturday morning?

Answer \_\_\_\_\_ [4]

7. Shape A is rotated  $90^\circ$  clockwise about (2,5) to give shape B.

Describe fully the single transformation which maps shape B back to shape A.

Answer \_\_\_\_\_  
\_\_\_\_\_ [3]

**Blank Page**

**8.**

(a) Draw and label the line  $y = 2x - 4$  on the grid opposite.

[2]

(b) Draw and label the line  $y = 5 - x$  on the grid opposite.

[2]

(c) Write down the coordinates of the point where the lines  $y = 2x - 4$   
and  $y = 5 - x$  intersect.

Answer \_\_\_\_\_ [1]



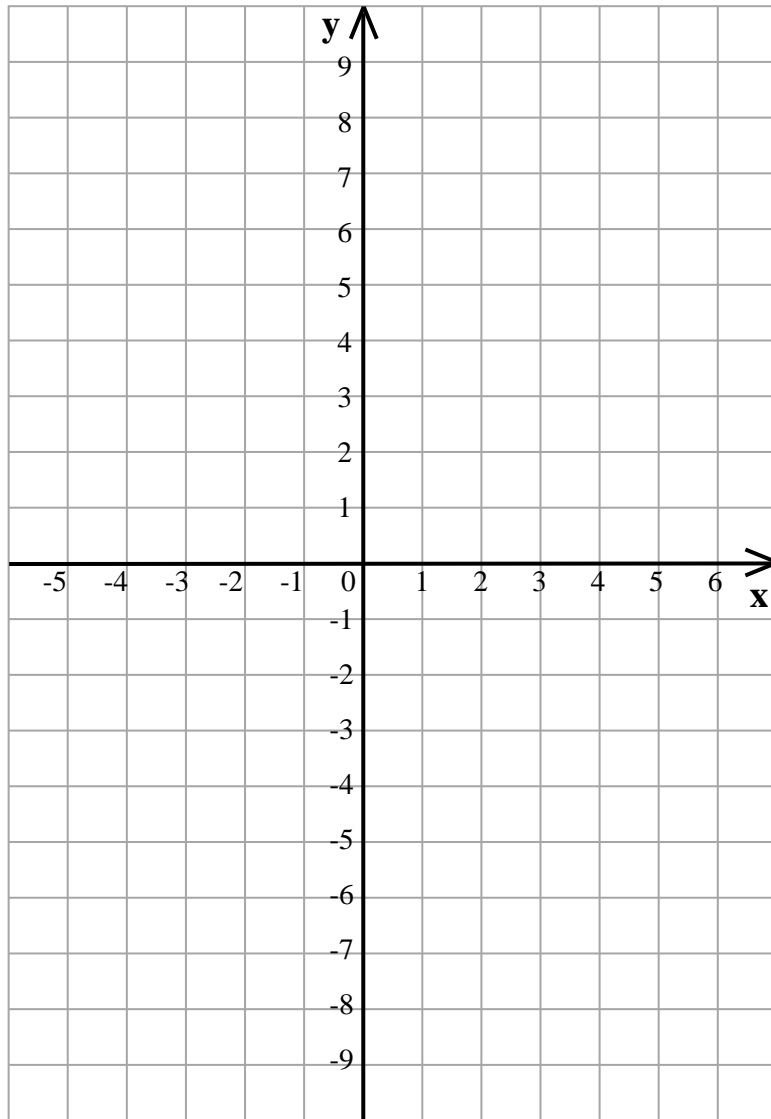

9. A fair spinner has the numbers 1, 2, 3 and 4 on it.

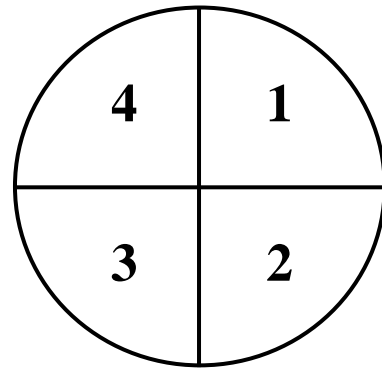

Jack spins the spinner once.

At the same time, he rolls a fair dice once.

He multiplies the 2 numbers together to get his final score.

(a) Show all the possible final scores in the table below.

	1	2	3	4	5	6
1						
2						
3						
4						

[2]

(b) Jack says he has a greater chance of getting a final score which is a multiple of 3 than getting a final score which is a multiple of 4.

Is he right?

Explain your answer.

Answer \_\_\_\_\_

\_\_\_\_\_

\_\_\_\_\_

[2]

**10.** The perimeter of a regular octagon is  $P$  cm.

Each side of the octagon is  $x$  cm.

Write a formula for  $x$  in terms of  $P$ .

Answer \_\_\_\_\_ [2]

11. ABCD is a square.

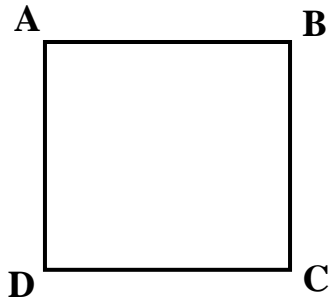

Write down

(a) The bearing of C from A

Answer \_\_\_\_\_<sup>o</sup> [1]

(b) The bearing of B from D

Answer \_\_\_\_\_<sup>o</sup> [1]

(c) The bearing of D from C

Answer \_\_\_\_\_<sup>o</sup> [1]

**12.** A sequence **S** has  $n$ th term  $5n - 3$

**(a)** Write down the first 4 terms in the sequence **S**.

Answer \_\_\_\_\_ [2]

**(b)** 10 is added to each of the terms in the sequence **S** to give a new sequence **N**.

What is the  $n$ th term of the sequence **N**?

Answer \_\_\_\_\_ [2]

13.

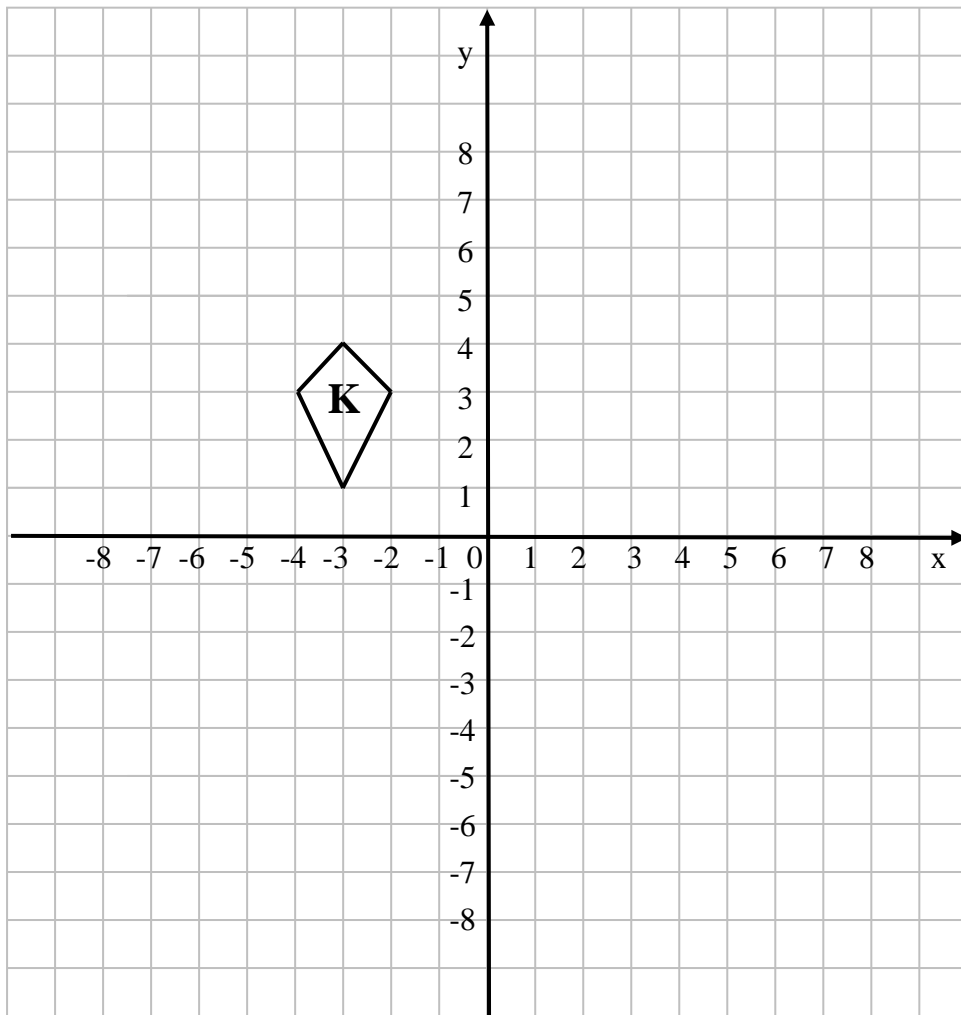

(a) Reflect shape K in the line  $x = 1$

Label the new shape A.

[2]

(b) Rotate shape K  $90^\circ$  anticlockwise about  $(0, -1)$

Label the new shape B.

[2]

14.

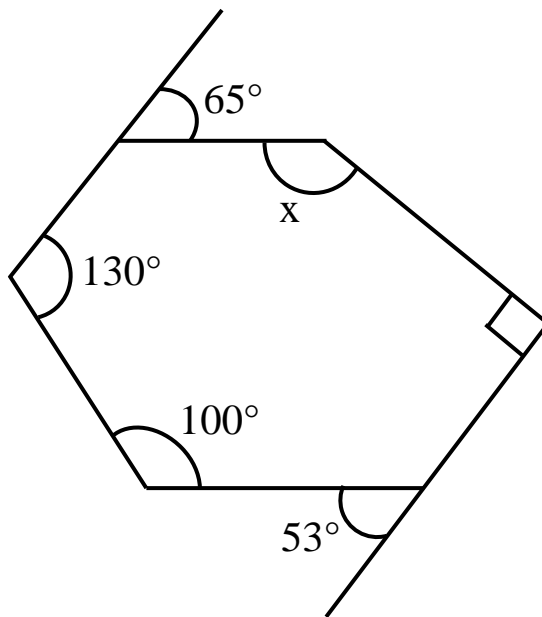

Diagram  
not drawn  
accurately

Work out the size of angle  $x$

Answer  $x =$  \_\_\_\_\_  $^\circ$  [4]

**15.** Jenny wants to investigate the likelihood of a drawing pin landing point up or point down when dropped.

She drops a drawing pin a number of times.

Her results are as follows;

up up down down down up down up up up up

Use Jenny's results to estimate how many times the pin will land point down after being dropped 150 times.

Answer \_\_\_\_\_ [3]



---

**THIS IS THE END OF THE QUESTION PAPER**

---