

FACTFILE: GCE TECHNOLOGY & DESIGN

1.6 METHODS OF PROCESSING MATERIALS PART 2



Methods of Processing Materials Part 2

Learning outcomes

Students should be able to:

- Demonstrate knowledge and understanding of:
 - forming including rolling, blanking, press forming and forging;
 - moulding including injection moulding, blow moulding, rotational moulding, vacuum forming, sand casting and pressure die casting; and
 - extrusion;

Course content

Rolling

Rolling is a process where a pair of metal rollers are rotating in the opposite direction to one another allow a piece of metal to be reduced in cross sectional area or shaped through deformation, as it passes through a gap between the rollers.

The metal being passed through the rotating metal rollers is originally larger than the gap.

A machine used for rolling metal is called a rolling mill. The picture across illustrates the rolling process.

Rolling process

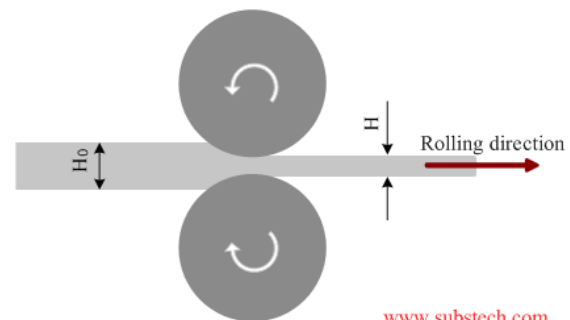

Materials used

Metals with high yield strength are normally used in the rolling process. Examples of these metals are:

- Iron
- Steel
- Copper
- Brass
- Aluminium alloys

What is Rolling used for?

The process of rolling is used in industry to make the following:

- Metal Bars
- Tin foil
- Sheets of metal

Blanking

Blanking is a metal fabricating process during which a metal work piece is removed from the primary metal sheet when it is punched. The punch is the shape and size of the component and the die has a corresponding hole. In order for blanking to take place the V ring plate and guide bars are required to keep each blank the same.

The **blank** is the material removed from the metal sheet. The diagram below illustrates this process.

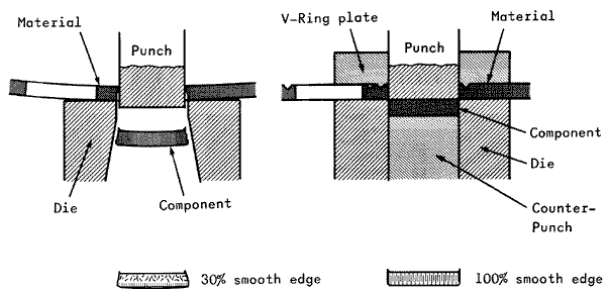

Materials used

The types of materials that are normally used in this process are sheets of metals such as:

- Aluminium alloys
- Brass
- Bronze
- Mild steel
- Stainless steel

What is Blanking used for?

Blanking can be used to create the following products:

- Gears
- Jewellery
- Watch or clock components

Press Forming (Cold Forming)

Press forming (cold forming) uses dies and punches to alter a blank sheet metal into an intricately shaped piece with the same volume.

A hydraulic ram presses the material into the die to create the final shape.

The shape depends on two parts which are:

• The Punch

The Punch is contained in the upper part of the machine and presses downwards causing the sheet metal to bend. This method provides precise control on the internal part features of the material being pressed.

• The Die

The Die confines and directs the material (sheet metal) into the shape required and provides precise control on the external part features.

The picture below shows the initial and final stage of press-forming:

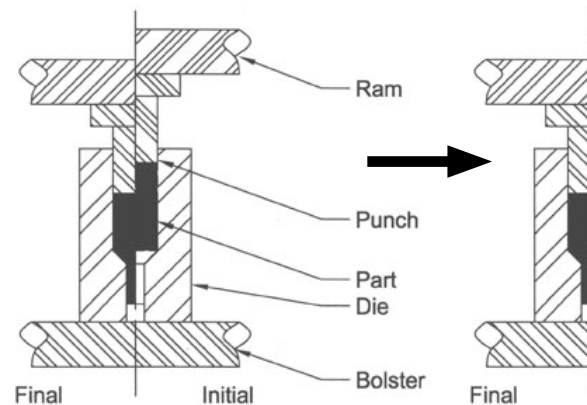

Materials used

The types of materials that are normally pressed are sheets of metal such as:

- Aluminium alloys
- Copper
- Brass
- Stainless Steel
- Lead

What is Press Forming used for?

The process of press-forming is used in industry to produce the following types of products:

- Kitchen utensils
- Pots
- Coins

Forging

Forging is a process by which metal is heated and is altered by deformation (Deformation is when a sufficient load is applied to a metal or other structural material, it will cause the material to change shape) by applying compressive force in particular places to achieve a desired shape. Usually the compressive force is in the form of hammer blows or a press.



Forging changes the grain formation of the metal which improves the physical characteristics.

Physical characteristics (such as ductility, toughness and strength) are improved in a forging compared to the base metal, which has crystals randomly scattered.

The picture below illustrates how a metal billet is altered by a forging press in order to achieve a final shape.

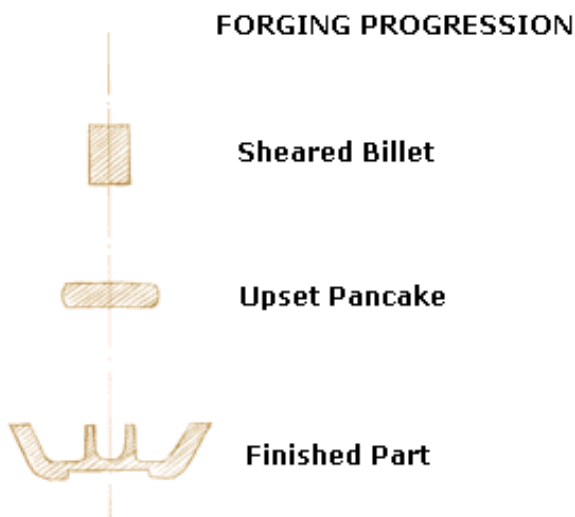

Materials used

The types of materials that are normally forged are:

- Aluminium alloys
- Copper Alloys (Brass)
- Steel/Mild
- Stainless Steel
- Iron

What is Forging used for?

Forgings are very strong and lightweight and are often used in the design of:

- Aircraft frame members
- Hammers
- Spanners

Injection Moulding

Injection moulding is a process used in the manufacturing industry to produce parts using thermoplastic and thermosetting plastics. This process is illustrated in the diagram below and operates as follows:

1. The plastic granules are poured into a hopper.
2. The heater in the is equipped with a reciprocating screw, which feeds the molten material into a teerature controlled split mould.
3. The liquid is pused into a mould where it will cool and form into shape
4. The mould is then opened and the formed material is taken out.

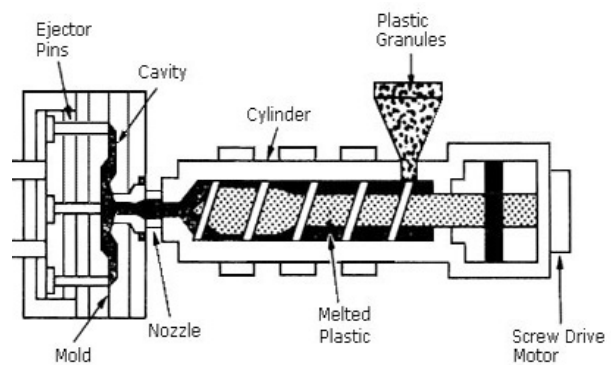

Materials used

The types of materials that are normally injected moulded are:

- Acrylonitrile-Butadiene-Styrene
- Nylon
- Polycarbonate
- Polypropylene
- Polystyrene

What is Injection Moulding used for?

The process of injection moulding is used in industry to produce the following:

- Power-tool housing
- Telephone handsets
- Television Cabinets
- Electrical Switches
- DVDs
- Automotive bumpers

Blow moulding

The process is similar to injection moulding. Blow moulding is used in the manufacturing industry to produce hollow plastic parts. This process is illustrated in the diagram below and operates as follows:

1. The plastic is fed in granular form into a hopper.
2. The material is driven into a large barrel which contains a screw thread which moves the material along a heated section.
3. In this heated section the granules become a liquid and are forced into the mould.
4. Air is then blown into the mould container which in turn pushes the plastic to the sides, giving the final shape.
5. The final mould is then cooled and is removed.

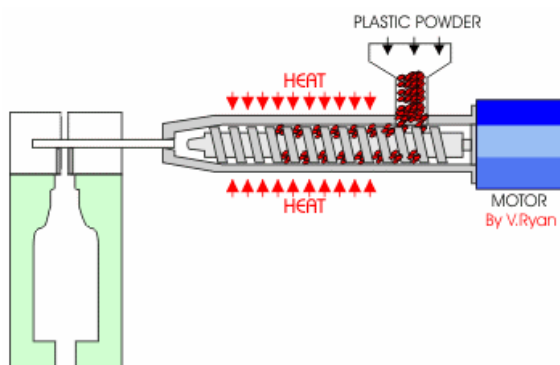
**Materials used**

The types of materials that are normally blow moulded are:

- Polypropylene
- Polythene
- PVC

What is Blow Moulding used for?

The process of blow moulding is used in industry to produce the following:

- All types of plastic bottles
- Toys
- Air ducts for automobiles
- Chemical & gasoline tanks
- Household goods

Rotational moulding

Rotational moulding is a plastic process suited for forming large hollow parts. The various stages involved in the process are illustrated in the diagram below.

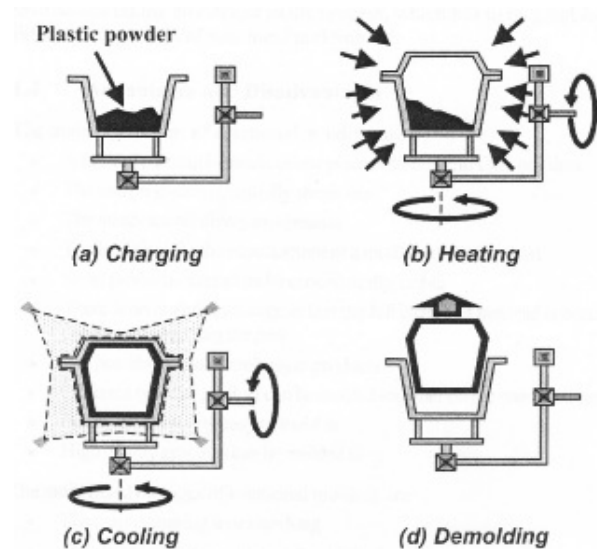
**Stages of Moulding:**

1. A mould is created according to the specifications for the finished product.
2. Polymer powder is placed in the mould (charging) which is then closed and placed in an oven.
3. Once inside the oven, the mould is rotated around two axes. When the plastic powder begins to melt it is forced to the outer walls and begins to stick.
4. When the polymer has been consolidated to the walls it is cooled either by air or water.
5. The polymer solidifies to the final shape.
6. When the polymer has cooled sufficiently and retains its shape the mould is then opened and the product removed.

Materials used:

The types of materials that are normally rotational moulded are:

- Polyethylene (Low Density)
- Polypropylene
- Ethylene Vinyl Acetate
- Polyvinyl Chloride
- PVC

What is Rotational Moulding used for?

The process of rotational moulding is used in industry to produce the following:

- Manhole inspection chambers
- Rainwater tanks
- Slides and climbing frames
- Diesel fuel tanks
- Children's playhouses
- Traffic cones
- Canoes and kayaks
- Pallets

Vacuum forming

Vacuum forming is the process of stretching a heated thermoplastic sheet around a mould and applying a vacuum pressure between the mould and plastic sheet.

The various stages involved in this process are illustrated in the diagram below and are as follows:

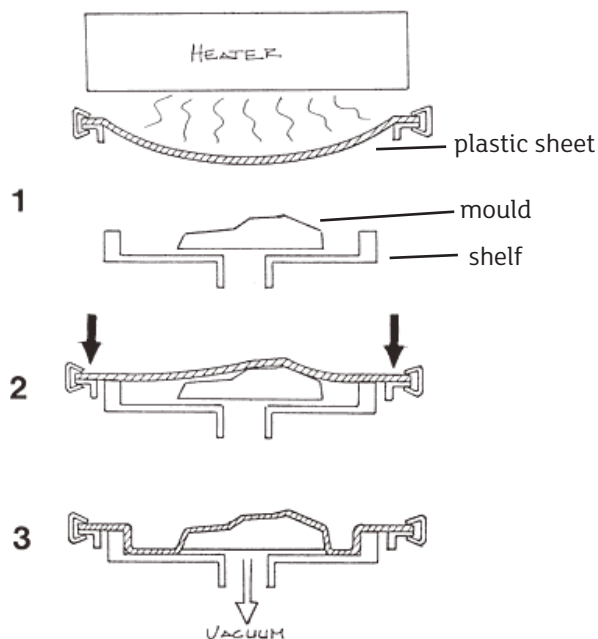

1. A mould is created according to the specifications for the finished product. This mould can be then used over and over again.
2. The mould is placed in the centre of the vacuum former.
3. A sheet of the chosen material is then placed and clamped into the required position.
4. The heater is then turned on. It will take about 5-10mins in order to get the heater to the required temperature. Once the temperature is correct the material will take between 4-6 minutes to heat.
5. The plastic will become pliable and flexible after a short time. It is important it is flexible enough in order to continue the process.
6. When the material is ready the shelf is then lifted up towards the sheet of material. The air underneath the former is pumped out (vacuum) and the material will then take the shape of the mould.

Materials used

The types of materials that are normally vacuum formed are:

- Acrylonitrile Butadiene Styrene
- Polyester Copolymer
- Polystyrene
- Polycarbonate
- Polypropylene
- Polyethylene (sheet and foamed sheet)
- Polyvinyl Chloride
- Acrylic

What is Vacuum Forming used for?

The process of vacuum forming is used in industry to produce the following:

- Baths & Shower Trays
- Yoghurt Pots
- Ski-Boxes
- Boat Hulls
- Machinery Guards
- Vehicle Door Liners
- Refrigerator Liners
- Sandwich Boxes
- Parts of vehicle

Sand casting

Sand casting is an ancient technique of using tightly packed sand to press around a model which is then removed leaving a mould cavity to be filled with molten metal. The diagram below illustrates the sand casting machine.

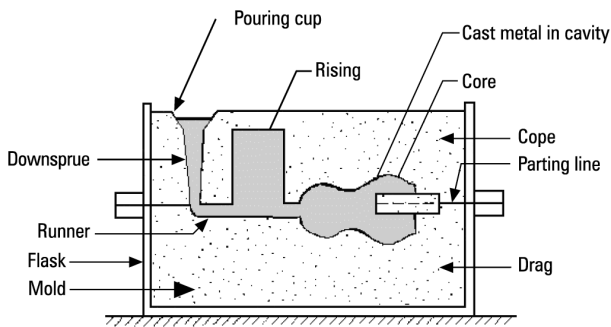

In the middle of the flask there is an impression device called a Pattern. The holding medium is the sand placed around the pattern which will then form the mould.

The various stages involved in this process are as follows:

1. In order to cast a product, the moulder will use the pattern to make the impression in the holding medium.
2. Then the pattern is removed and the impression is left in the sand.
3. The cope and drag are closed, to complete the flask, which forms the complete mould, with the impression of the pattern captured in the sand.
4. The molten material is added through a gap at the top
5. When all the molten material is in the mould it is left to cool.
6. Once cooled the flask is open and the mould complete.

Materials used

The types of materials that are normally sand casted are:

- Alloy Steel
- Carbon Steel
- Cast Iron
- Stainless Steel
- Aluminium alloys
- Copper
- Magnesium
- Nickel

What is Sand Casting used for?

The process of sand casting is used in industry to produce the following:

- Fan blades
- Ornaments
- Machine frames

Pressure Die Casting

The basic die casting process involves injecting molten metal under extremely high pressure into a steel mould called a die which can be highly intricate.

There are two methods of die casting either using a hot chamber or cold chamber.

To do a die cast it will vary from one second for smaller parts to a couple of minutes for larger casting.

The diagram below illustrates the pressure die casting process:

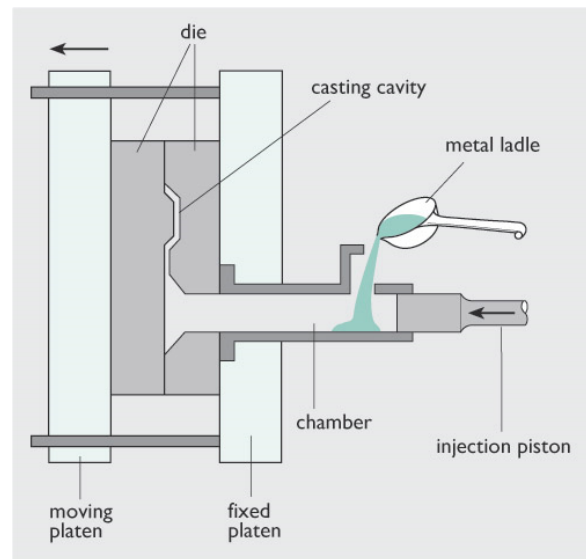

1. A die is created according to the specifications for the finished product.
2. The die is clamped between the moving platen and the fixed platen.
3. Molten metal is injected under high pressure into a steel die.
4. The mould is then cooled in the die.
5. Once cooled the moving platen will open allowing the mould to be released.

Materials used

The type of materials that are normally pressure die casted are:

- Aluminum alloys
- Zinc
- Copper

What is Pressure Die Casting used for?

The process of sand casting is used in industry to produce the following:

- Disk drives
- Toys
- Sink faucet
- Connector housing

Extrusion

Extrusion is a process in which material is forced through a die to create objects of a fixed cross sectional profile.

The machine used to extrude materials is very similar to the injection moulding machine. The various stages involved in the process of polymer extrusion are illustrated in the diagram below:

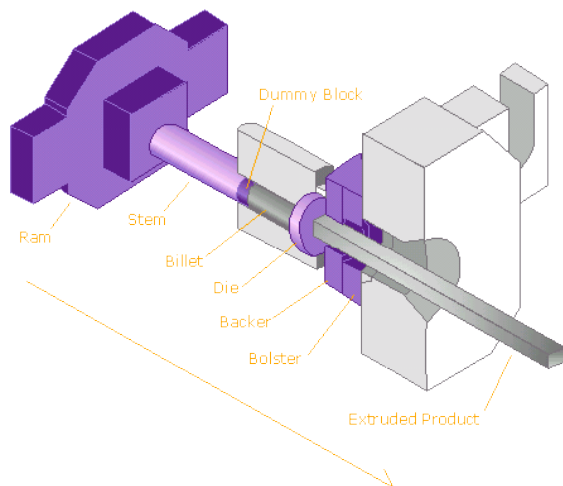

1. Thermoplastic granules are placed in the hopper.
2. A motor then turns the screw thread which moves the granules along past a heater where the granules become molten.
3. The molten thermoplastic is then forced through a die to form the extrusion.
4. The extrusion is then cooled
5. The shape of the die determines the shape of the final product

Thermoplastics are used as when they are heated and then pressured through a mould they can be formed into different shapes and sections.

The extrusion process can be applied to various materials e.g. most metals, polymers, ceramics etc. The process will vary according to the material.

Materials used

The type of materials that are normally extruded are:

- Polystyrene
- Nylon
- Polypropylene
- Polythene
- Metals e.g. aluminium alloys, copper

What is Extrusion used for?

The process of extrusion is used in industry to produce the following:

- Plastic tubing
- Pipes
- Rods
- Rails
- Sheets

? Revision Questions

1 With the aid of an annotated sketch, describe the rolling process.



2 Litter bins, storage tanks and traffic bollards are manufactured by the process of rotational moulding.

(i) State one main reason why rotational moulding is the most suitable process for the manufacture of these products.



(ii) Suggest a suitable material for the rotational moulding process.



(iii) With the aid of an annotated sketch, describe the rotational moulding process.

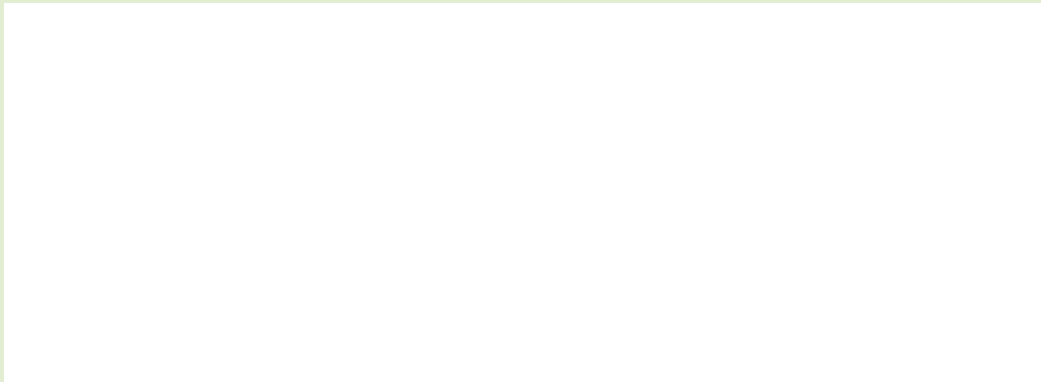



Revision Questions

3

Components such as metal washers can be produced by the process of blanking.

(i) In what common form should the metal be supplied in order to be used for the blanking process?

.....

(ii) With the aid of an annotated sketch, describe the blanking process.

.....

4

Garden patio chairs are manufactured by injection moulding.

(i) Give **two** main reasons why injection moulding is the most suitable process for this product.

.....
.....

(ii) Suggest a suitable material for the injection moulding process.

.....

(iii) With the aid of an annotated sketch describe the injection moulding process.

.....

