



Rewarding Learning

General Certificate of Secondary Education
2023–2024

Centre Number

--	--	--	--	--

Candidate Number

--	--	--	--

Single Award Science: Chemistry

Unit 2

Foundation Tier

MV24

[GSA21]

THURSDAY 22 FEBRUARY 2024, MORNING

Time

1 hour, plus your additional time allowance.

Instructions to Candidates

Write your Centre Number and Candidate Number in the spaces provided at the top of this page.

You must answer the questions in the spaces provided.

Do not write on blank pages.

Complete in black ink only.

Answer **all nine** questions.

Information for Candidates

The total mark for this paper is 60.

Figures in brackets printed at the end of each question indicate the marks awarded to each question or part question.

Quality of written communication will be assessed in Question 9.

A Data Leaflet, which includes a Periodic Table of the Elements, is included for your use.

Blank Page

(Questions start overleaf)

- 1 (a) The diagram below shows how particles are arranged in a solid and a liquid.

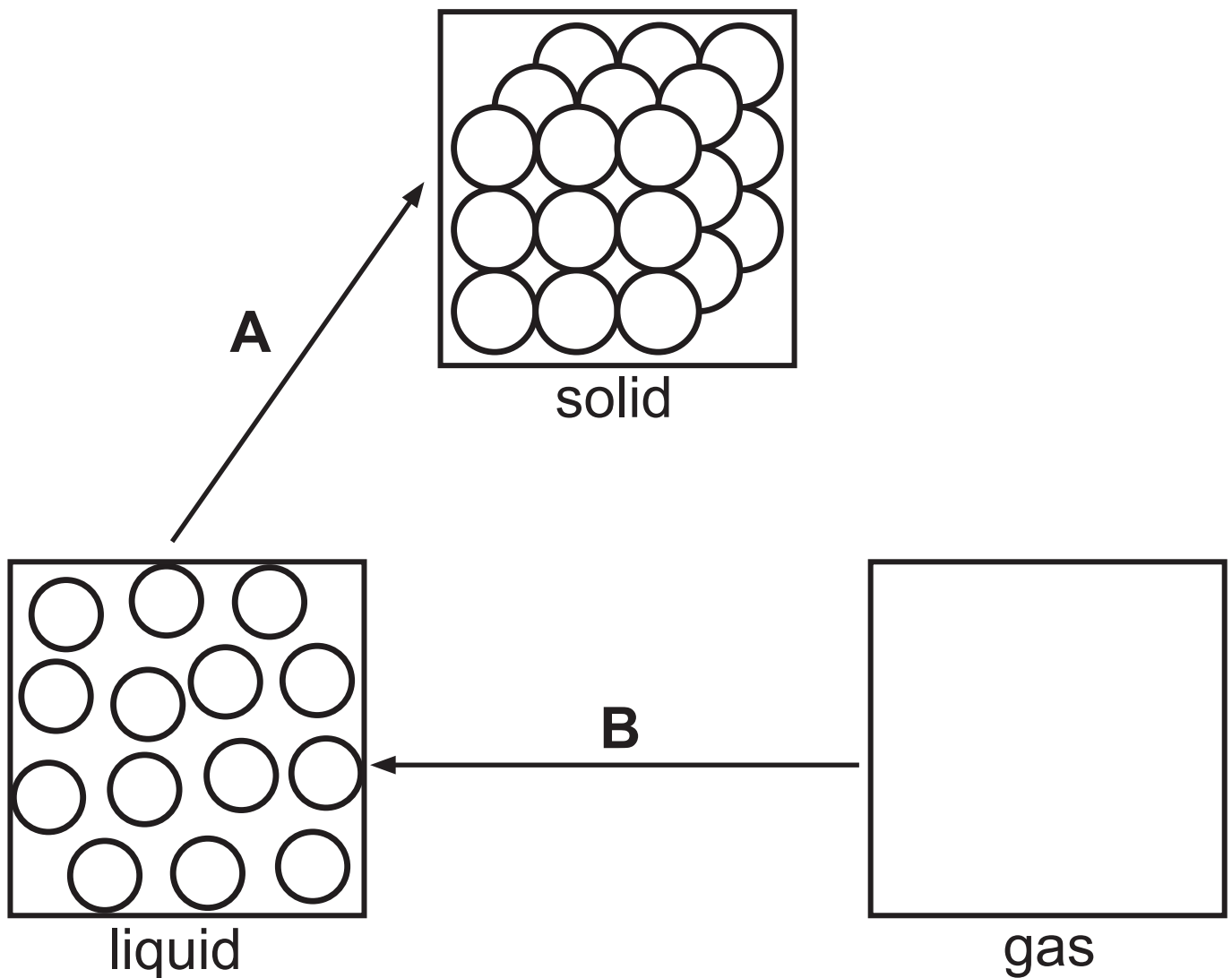

- (i) Complete the diagram to show how particles are arranged in a **gas**.
[1 mark]

(ii) Name the changes that are labelled **A** and **B** in the diagram.

Choose from:

melting

evaporating

freezing

condensing

[2 marks]

A _____

B _____

(b) Complete the following sentences.

Choose from:

solvent

solution

soluble

[2 marks]

A solid that dissolves in a liquid is described as _____.

The liquid that dissolves the solid is called the _____.

2 A mixture is a substance that can be easily separated.

(a) On the page opposite, use lines to match each mixture to the apparatus that can be most easily used to separate it.
[2 marks]

(b) Complete the following sentence.
[1 mark]

A single element or compound not mixed with any other substance is described as being a _____ substance.

Mixture

Apparatus

sand
and water

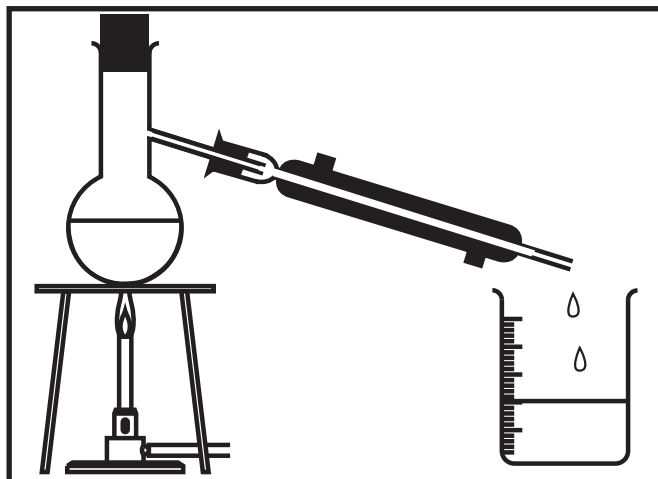

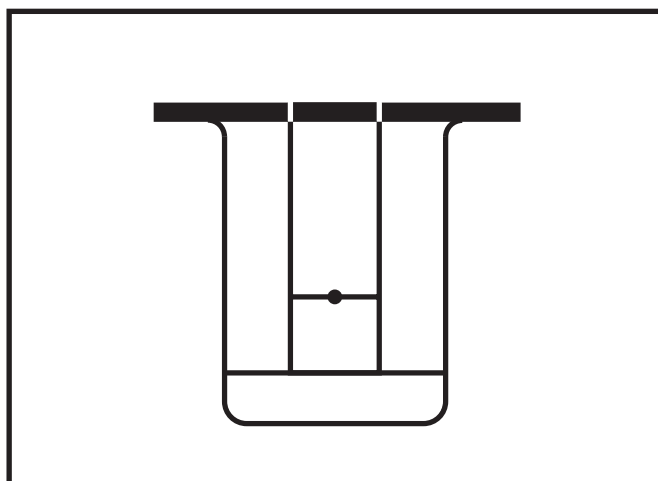
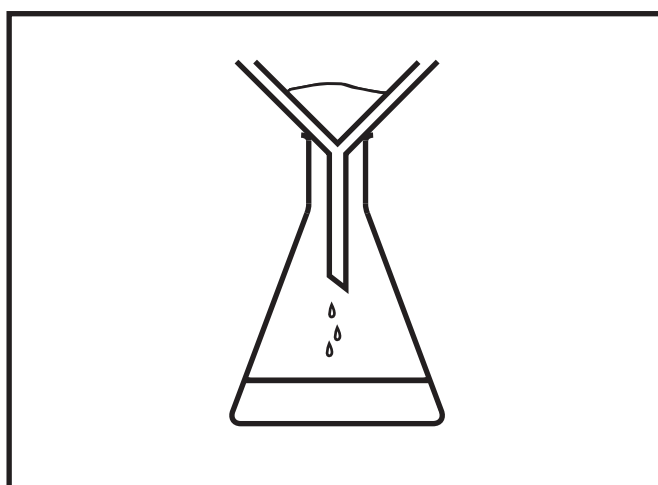

alcohol
and water



3 (a) A bottle of sulfuric acid is labelled with a symbol to show the contents are **corrosive**.

(i) In the table below place a tick (✓) to show which symbol is used on a bottle of sulfuric acid.

[1 mark]

Symbol	Tick (✓)
	
	
	

(ii) Complete the sentence below.
[1 mark]

These symbols are used as a warning and they are called _____ symbols.

(iii) Sulfuric acid has a pH of 1. What colour would you expect universal indicator paper to be when dipped into sulfuric acid? [1 mark]

(b) Some foods contain acid and can make the conditions in our mouth more acidic, causing tooth decay. Many people use toothpaste after eating to help avoid tooth decay.



- (i) Use this information and your knowledge to complete the sentences below.

Choose from:

strong

clean

neutralise

weak

concentrated

[2 marks]

Toothpaste has a pH of 8 and is a _____ alkali.

Using toothpaste after eating helps to _____ the acid in our mouths.

- (ii) Complete the word equation below to give the general reaction that takes place when an acid reacts with an alkali. [2 marks]



4 Plastic is described as a synthetic material.

(a) What is meant by the term **synthetic**?
[1 mark]

The table below gives information about five different types of plastic.

Plastic	Properties	Cost
nylon	Strong, lightweight, long-lasting, tough, resistant to chemicals.	high
polythene	Soft, flexible, low melting point, lightweight, resistant to chemicals.	low
PVC	Hard, weather resistant, keeps its shape, can be coloured, brittle.	medium
kevlar	Strong, long-lasting, heat-resistant, flexible, lightweight.	very high
polystyrene	Rigid, lightweight, good heat insulator, moderately strong, waterproof.	low

Use this information to answer the following questions.

(b) Name the plastic that would be best for making:

a cup for hot drinks.

a window frame.

[2 marks]

(c) Kevlar has many uses, including protective clothing. Give **one** advantage and **one** disadvantage of using kevlar to make gloves worn by firefighters.
[2 marks]

Advantage

Disadvantage

(d) The pie chart below shows how household plastic waste was disposed of during one week in part of the UK.

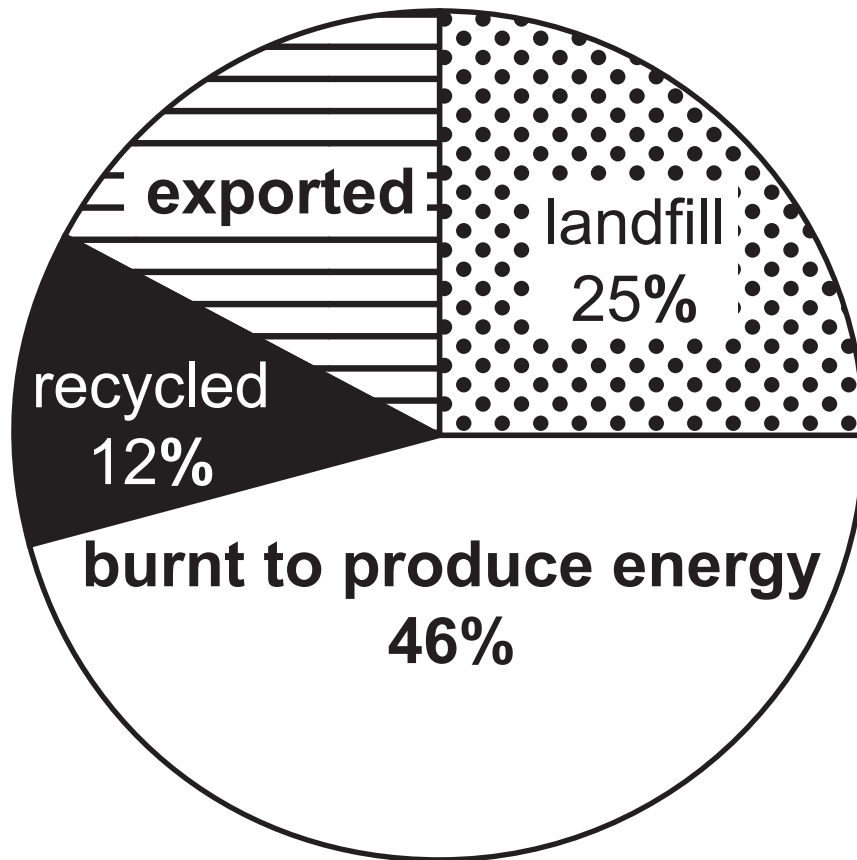

(i) Calculate the percentage of plastic waste which is **exported**.

(Show your working out.) [2 marks]

_____ %

(ii) Give one advantage and one disadvantage of sending plastic waste to landfill. [2 marks]

Advantage

Disadvantage

5 An outline of the Periodic Table is shown below.

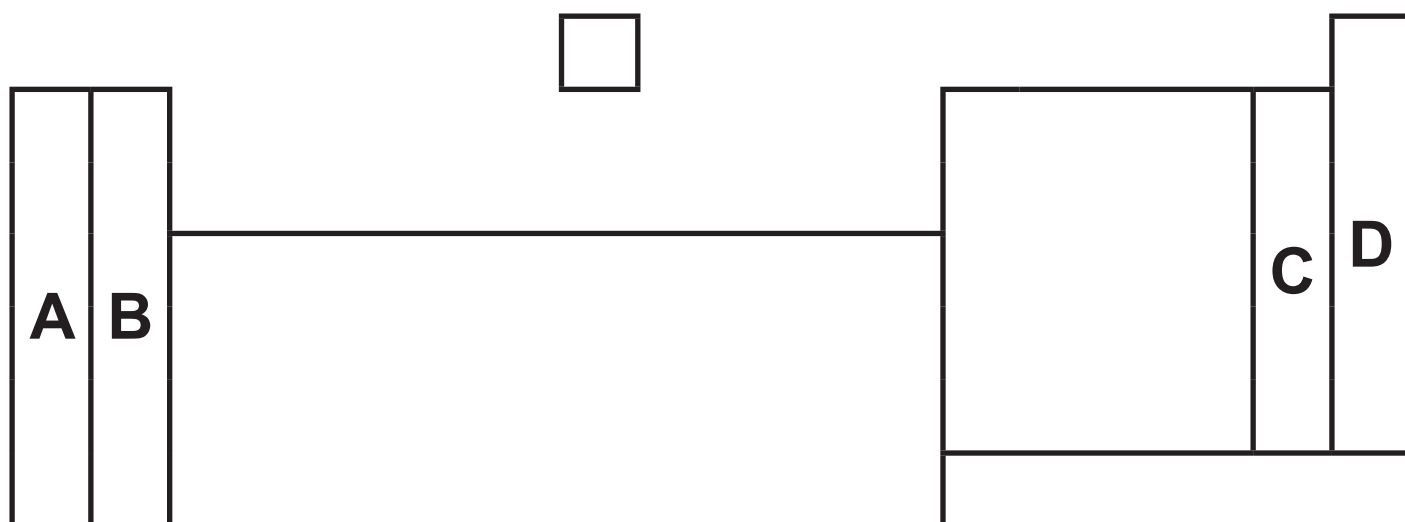

(a) Which letter **A**, **B**, **C** or **D** shows the position of:

the alkali metals? _____

the noble gases? _____
[2 marks]

(b) Complete the following sentence.

Choose from:

block

period

physical

group

chemical

[2 marks]

Elements in the same _____
of the Periodic Table have the same
number of electrons in their outer
shell and this gives them similar
_____ properties.

(c) Dmitri Mendeleev was a Russian scientist who designed the first periodic table.

(i) In what order did he arrange the elements in his periodic table?
[1 mark]

(ii) Why did Dmitri Mendeleev leave gaps in his periodic table? [1 mark]

6 Crude oil is a very useful resource and the main source of hydrocarbons.

(a) Describe how crude oil is formed.

[3 marks]

(b) Combustion of hydrocarbon fuels is a major source of atmospheric pollution and can lead to an increase in the greenhouse effect.

(i) Name **one** gas released when hydrocarbons are burnt. [1 mark]

(ii) Give **two** environmental problems caused by the greenhouse effect.
[2 marks]

1. _____
2. _____

(c) The first hydrocarbon in the alkane family has the formula CH_4 .

(i) What is the chemical name of the first member of the alkane family (CH_4)?
[1 mark]

(ii) Name the **two** elements found in all hydrocarbons. [1 mark]

_____ and _____

Butane is another alkane, it has the formula C_4H_{10} .

(d) In the space below draw the structural formula for butane. [1 mark]



7 (a) Hydrogen reacts with chlorine to produce hydrogen chloride.

The diagram below shows how hydrogen and chlorine bond by **sharing** one pair of electrons.

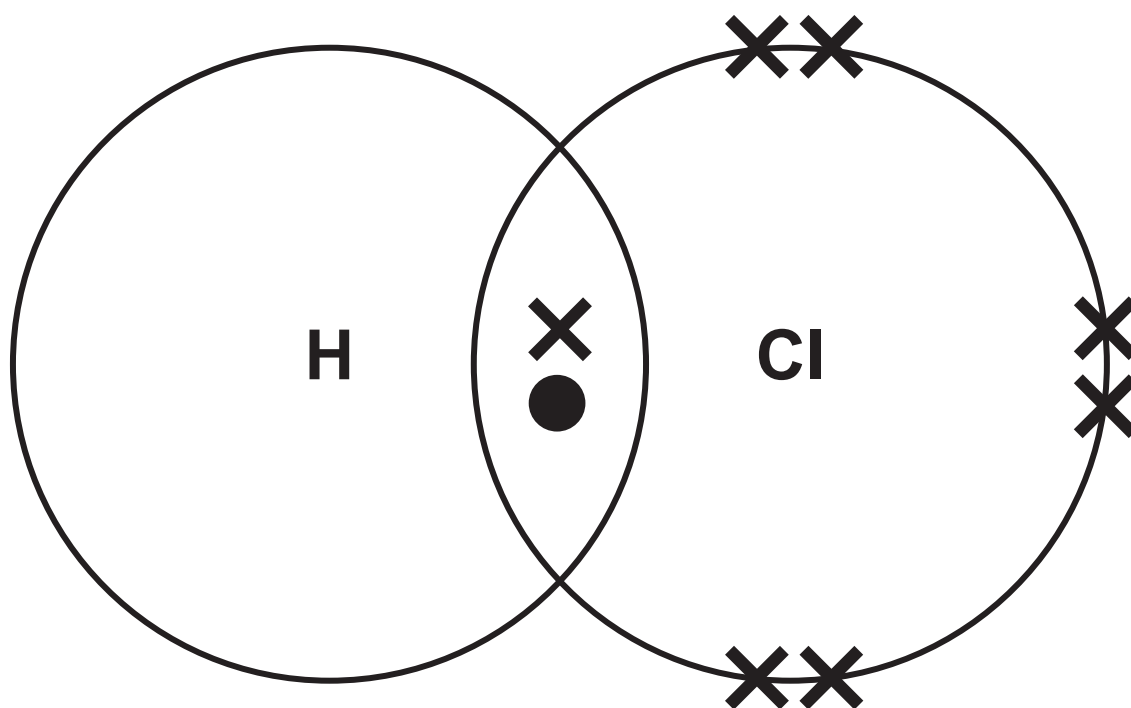

(i) Name the **type** of chemical bonding that occurs between hydrogen and chlorine. [1 mark]

(ii) What is the formula for hydrogen chloride? [1 mark]

Circle your answer.



(b) Ammonium chloride (NH₄Cl) is another compound containing chlorine.

(i) How many **elements** are in ammonium chloride (NH₄Cl)? [1 mark]

(ii) How many **atoms** are represented by the formula NH₄Cl? [1 mark]

- 8 (a) Three metals (zinc, copper and lithium) were separately added to cold water and dilute acid. If a reaction occurred a ✓ was recorded and if no reaction occurred an ✗ was recorded.

The results are shown below.

	zinc	copper	lithium
cold water	✗	✗	✓
dilute acid	✓	✗	✓

- (i) Use this information to complete the reactivity series below by placing the metals zinc, copper and lithium in their correct positions. [1 mark]

sodium	most reactive  least reactive
magnesium	
aluminium	
iron	

A flame test can be used to identify metal ions.

- (ii) Name the metal ion that produces a yellow-orange flame. [1 mark]
-

(b) Magnesium and an unknown metal **X**, were each reacted with excess dilute hydrochloric acid. The volume of hydrogen gas given off during each reaction was measured.

The results are shown below.

	Time/min	0	1	2	3	4	5	6	7
Volume of gas /cm ³	Metal X	0	23	36	40	40	40	40	40
	Magnesium	0	14	25	33	37	40	40	40

- (i)** The results for metal **X** are plotted on the grid opposite.
On the same grid, plot and draw the line graph for magnesium.
[3 marks]

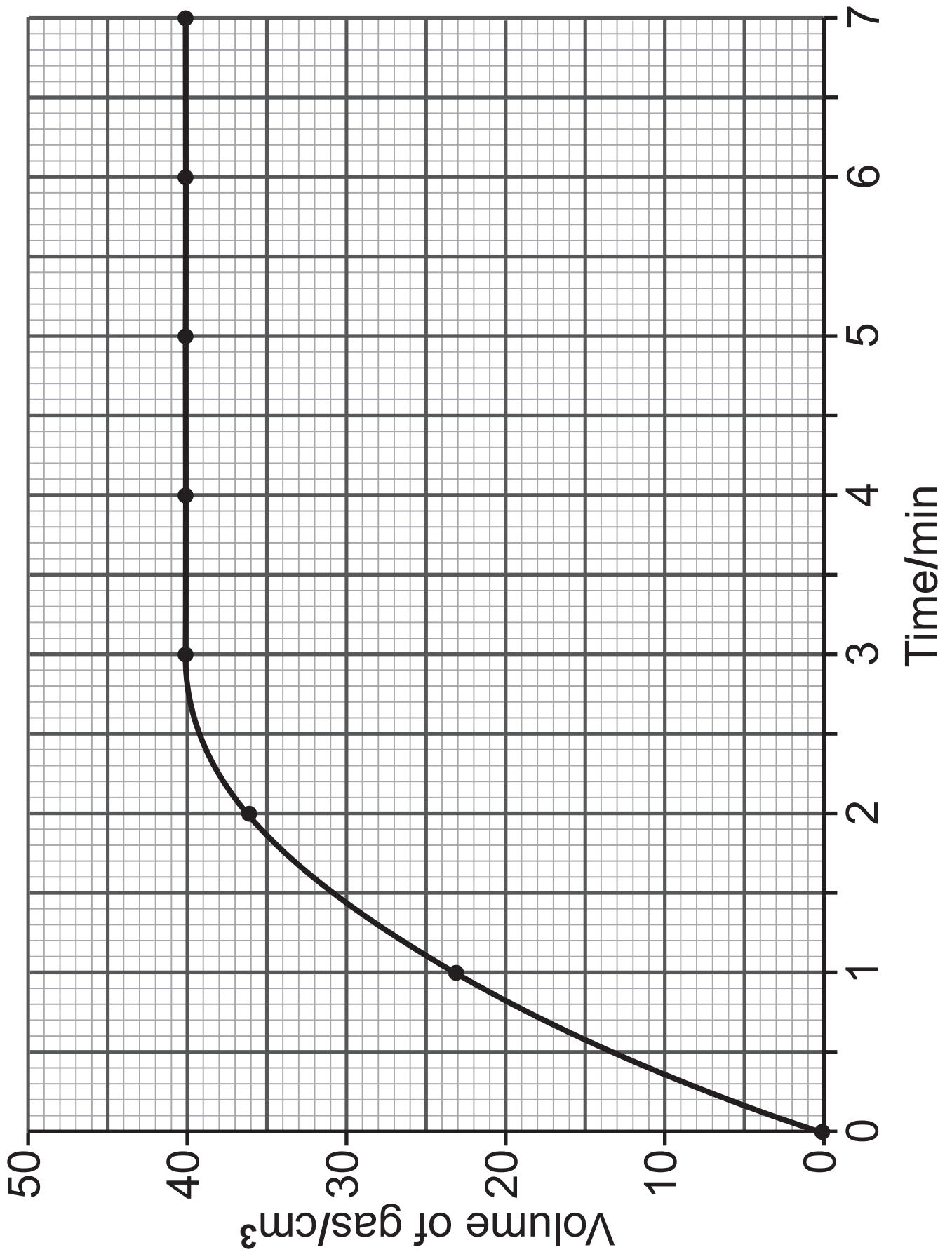

(ii) Describe fully the trend for metal **X**.
[2 marks]

(iii) A student concludes that metal **X** is more reactive than magnesium. How do the results show the student is correct? [1 mark]

(iv) Complete the word equation below for the reaction of magnesium with hydrochloric acid. [1 mark]

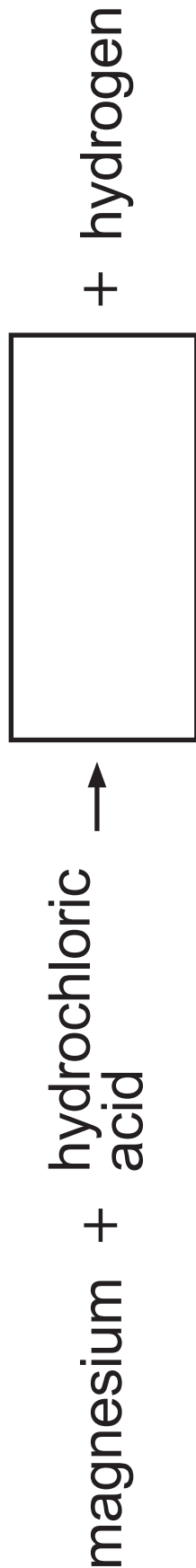

(v) The student tested the gas produced with a lit splint. What would he observe? [1 mark]

(vi) When magnesium is added to hydrochloric acid there is an increase in temperature. What name is given to a reaction that gives out heat? [1 mark]

Blank Page

(Questions continue overleaf)

9 The element lithium is represented on the Periodic Table as shown below.

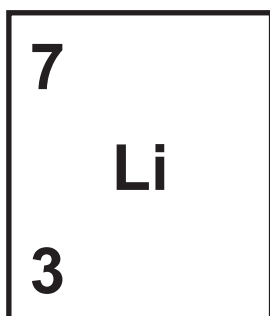

With reference to the structure of a lithium atom, describe how a lithium ion is formed.

Your answer should include:

- the name, number and location of the three sub-atomic particles found in a lithium atom; and
- how a lithium ion forms from a lithium atom. [6 marks]

In this question you will be assessed on your written communication skills including the use of specialist scientific terms.

This is the end of the question paper

SOURCES

Q1. © Getty Images
Q2(a) . . . Principal Examiner × 3
Q3(a) . . . © Getty Images × 3
Q3(b) . . . © Getty Images
Q7(a) . . . Principal Examiner

For Examiner's use only	
Question Number	Marks
1	
2	
3	
4	
5	
6	
7	
8	
9	
Total Marks	

Examiner Number

Permission to reproduce all copyright material has been applied for.
In some cases, efforts to contact copyright holders may have been unsuccessful and CCEA will be happy to rectify any omissions of acknowledgement in future if notified.