



Rewarding Learning

ADVANCED SUBSIDIARY (AS)
General Certificate of Education
2024

Centre Number

--	--	--	--	--

Candidate Number

--	--	--	--	--

Physics

Assessment AS 3A
assessing
Practical Techniques
and Data Analysis



[SPH31]

SPH31

TUESDAY 7 MAY, MORNING

TIME

1 hour.

INSTRUCTIONS TO CANDIDATES

You must not communicate with any other candidate.

Write your Centre Number and Candidate Number in the spaces provided at the top of this page.

You must answer the questions in the spaces provided.

Do not write outside the boxed area on each page, or on blank pages.

Complete in black ink only. Do not write with a gel pen.

The Teacher/Supervisor will tell you the order in which you are to answer the questions.

One hour is to be spent on four short experimental tests.

After 12 minutes you must stop using the apparatus so that it can be rearranged for the next candidate. At 14 minutes you will be instructed to move to the station for the next question.

At the end of the test a 4 minute period will be provided for you to complete your answer to any question, but you will not have access to the apparatus during this time.

INFORMATION FOR CANDIDATES

The total mark for this paper is 40.

Figures in brackets printed down the right-hand side of pages indicate the marks awarded to each question or part question.

14207



16SPH3101

1 In this experiment you will investigate the relationship between the frequency of a tuning fork and the length of the air column when resonance occurs.

You are provided with a measuring cylinder containing water, a moveable open-ended resonance tube and a half metre rule. In addition, you are provided with three tuning forks, whose frequencies are clearly labelled.

A diagram of the experimental apparatus is shown in **Fig. 1.1**.

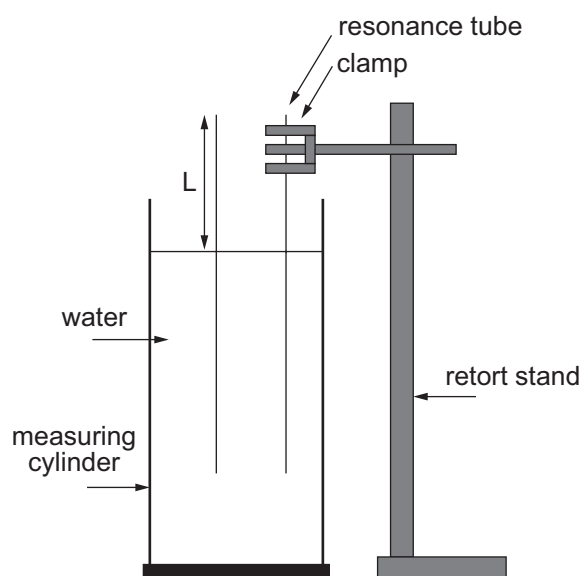

Fig. 1.1

- (a) (i)** Record the frequency F of each tuning fork in order, starting with the smallest frequency, in **Table 1.1**. [1]

Gently strike a tuning fork on the rubber bung and hold the vibrating tuning fork just above the open end of the resonance tube. Slowly lift the resonance tube and tuning fork and stop when the first mode of vibration is detected. Tighten the clamp to hold the resonance tube at this position.

- (ii)** Measure the length L of the air column and record this reading in **Table 1.1**. Only one value of L is required for each tuning fork. [1]

- (iii)** Repeat this procedure for the remaining two tuning forks and record these readings in **Table 1.1**. [1]



Table 1.1

F / Hz	L / cm	

(b) There is an uncertainty associated with reading to the smallest division on the scale of the half metre rule.

(i) Identify two other sources of uncertainty associated with measuring the length of the air column when the first mode of vibration is detected.

1. _____

2. _____

_____ [2]

(ii) Estimate the total uncertainty in the reading of the length of the air column.

Uncertainty = \pm _____ cm [1]

(c) (i) Calculate a value for $F \times L$ and record this value to an appropriate number of significant figures in the third column of **Table 1.1**. Include a heading. [3]

(ii) Is F inversely proportional to L ? Explain your answer.

_____ [1]

[Turn over



2 In this experiment you will investigate the relationship between the period of oscillation T of a lath, and its length L .

The apparatus has been set up as shown in **Fig. 2.1**.
Two different laths have been provided.

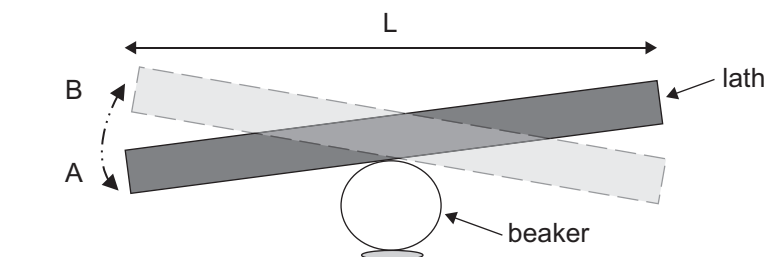

Fig. 2.1

- (a) Use the metre rule to measure the length L of the **shortest** lath and record it in **Table 2.1**.

Rebalance this lath on top of the beaker and push down gently on one end to create oscillations of small amplitude. The period of oscillation T is the time taken for the end of the lath to move from A to B and back to A again.

Take sufficient measurements to determine an accurate and reliable value for the period of oscillation T for this lath.

Repeat this procedure for the second lath.

Record all your readings in **Table 2.1**. Include appropriate headings. [7]

Table 2.1

L / cm		T / s



(b) The relationship between T and L is given by **Equation 2.1**.

$$T = bL \quad \text{Equation 2.1}$$

where b is a constant.

Use your results to determine a value for b. Include a unit with your answer.

b = _____

Unit of b = _____

[3]



3 In this experiment you will determine the density of cardboard using a hexagonal lamina.

You have been provided with a regular hexagonal lamina with a circular hole as shown in **Fig. 3.1**.

The area of a regular hexagon is given by **Equation 3.1**.

$$\text{Area of hexagon} = \frac{3}{4} AB \quad \text{Equation 3.1}$$

where A and B are the lengths shown on **Fig. 3.1**.

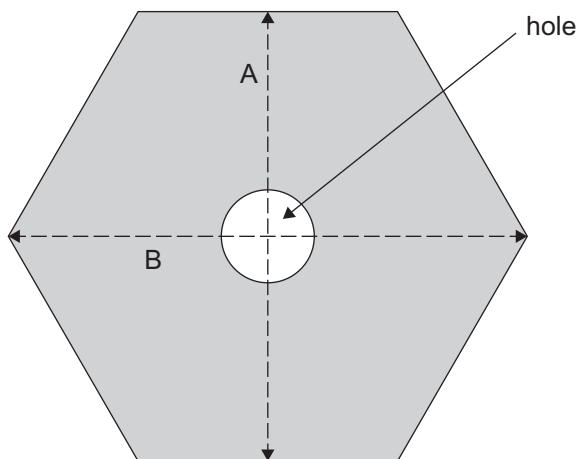

Fig. 3.1

You have been provided with the following measuring instruments:

- micrometer screw gauge
- vernier caliper
- top pan balance
- ruler

(a) Choose the most suitable measuring instrument and measure:

- the lengths A and B of the hexagonal lamina.
- the diameter d of the hole in the centre of the hexagonal lamina.
- the thickness t of the hexagonal lamina.

State the name of the measuring instrument used in each case and record the values in **Table 3.1**. Include an appropriate unit where required.



Table 3.1

Quantity	A / cm	B / cm	d / _____	t / _____
Measuring instrument				
Value				

[4]

(b) Use the top pan balance to measure the mass m of the lamina.

$m =$ _____ g

[1]

(c) Use values from **Table 3.1** to calculate the area of the lamina as shaded in **Fig. 3.1**.

Area = _____ cm^2

[3]

[Turn over



(d) Use the answers to (b) and (c) with other values recorded in **Table 3.1** to determine the density of the cardboard lamina.

Density = _____ g cm⁻³

[2]





BLANK PAGE

DO NOT WRITE ON THIS PAGE

(Questions continue overleaf)

14207

[Turn over



16SPH3109

4 In this experiment you will measure values of voltage and resistance.

- (a)** You have been provided with two cells, two resistors X and Y, an ohmmeter labelled Ω , and a voltmeter labelled V.

The circuit in **Fig. 4.1** has been set up for you.

CIRCUIT 1

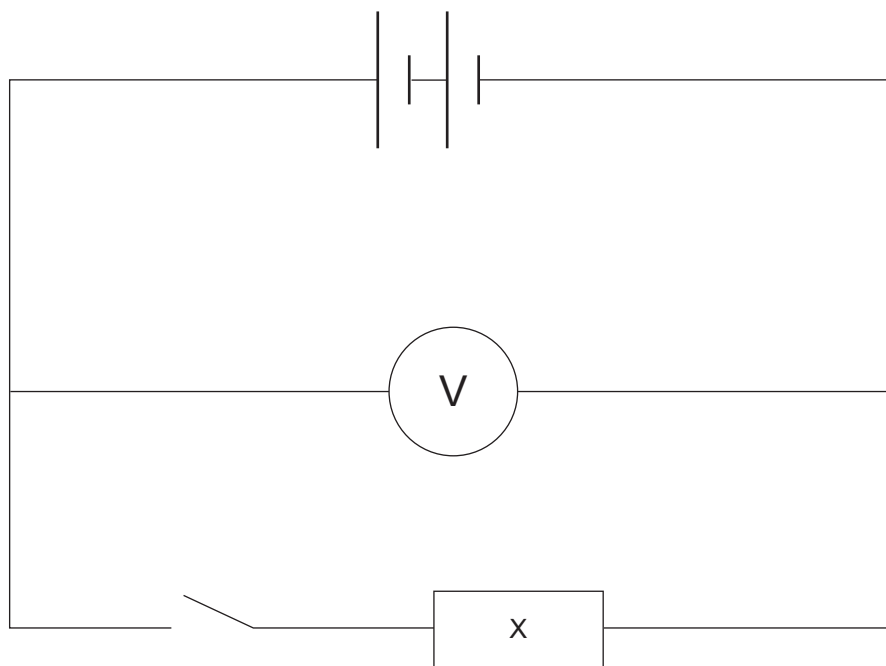

Fig. 4.1

- (i)** Using this circuit, close the switch and record the voltmeter reading.

Voltmeter reading = _____ V

[1]



Add resistor Y to the circuit as shown in Fig. 4.2.

CIRCUIT 2

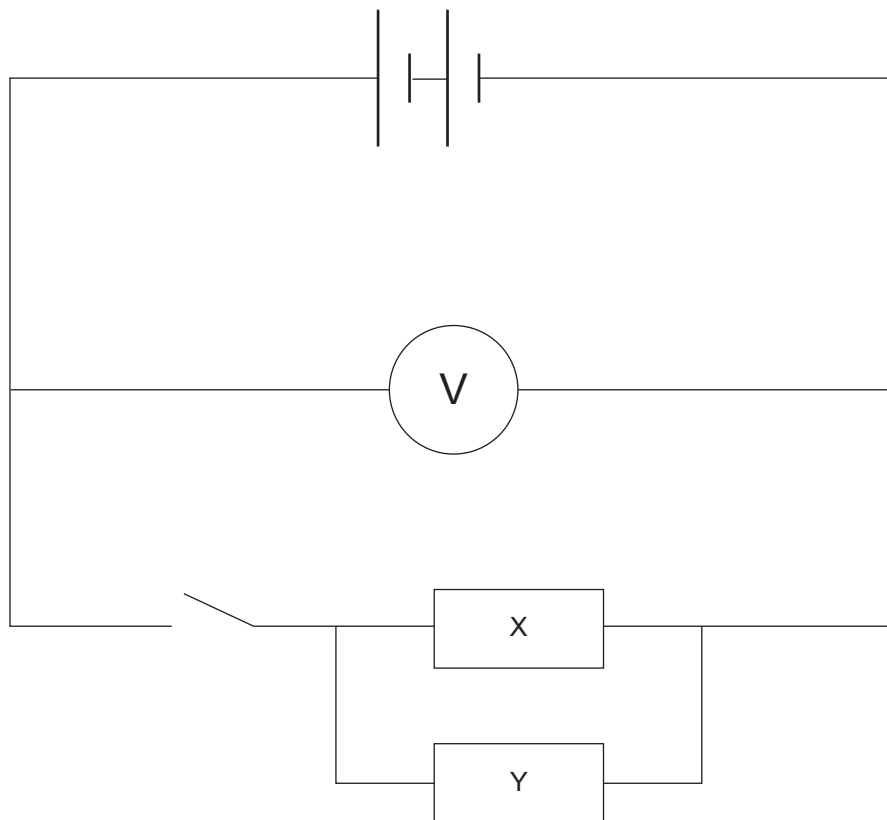

Fig. 4.2

(ii) Close the switch and record the voltmeter reading.

Voltmeter reading = _____ V

[1]



Now move resistor Y to the position shown in Fig. 4.3.

CIRCUIT 3

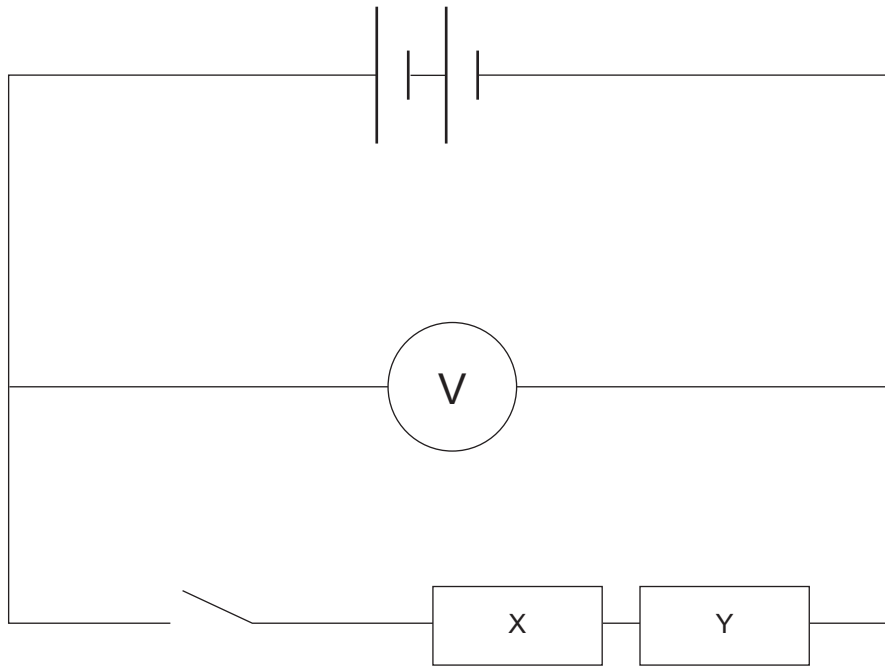

Fig. 4.3

(iii) Close the switch and record the voltmeter reading.

Voltmeter reading = _____ V [1]

(b) (i) Remove resistors X and Y from the circuit. Measure and record the resistance of X and then Y using the ohmmeter.

Resistance of X = _____ Ω

Resistance of Y = _____ Ω [2]

(ii) Using knowledge of series and parallel circuits, place CIRCUITS 1, 2 and 3 in order of their total resistance, from lowest to highest resistance.

CIRCUIT _____ CIRCUIT _____ CIRCUIT _____ [1]



(iii) What is the trend in the values of voltage as the circuit resistance increases? Suggest a reason for this trend.

[2]

(c) The percentage uncertainty in each resistor reading is $\pm 5\%$. Calculate the total resistance and the absolute uncertainty in the value of the total resistance in CIRCUIT 3.

Total resistance = _____ Ω

Absolute uncertainty = _____ Ω

[2]

THIS IS THE END OF THE QUESTION PAPER



BLANK PAGE
DO NOT WRITE ON THIS PAGE

14207



16SPH3114





BLANK PAGE

DO NOT WRITE ON THIS PAGE

14207



16SPH3115

DO NOT WRITE ON THIS PAGE

For Examiner's use only		
Question Number	Marks	Remark
1		
2		
3		
4		
Total Marks		

Permission to reproduce all copyright material has been applied for.
In some cases, efforts to contact copyright holders may have been unsuccessful and CCEA will be happy to rectify any omissions of acknowledgement in future if notified.

SPH31/5
291512





Rewarding Learning

**ADVANCED SUBSIDIARY (AS)
General Certificate of Education
2024**

Physics

Assessment Unit AS 3A

Practical Techniques and Data Analysis

[SPH31]

TUESDAY 7 MAY, MORNING

APPARATUS AND MATERIALS LIST

To be accessed by Head of Department only.

PHYSICS UNIT 3 (AS 3A)
APPARATUS AND MATERIALS REQUIRED FOR PRACTICAL ASSESSMENT

CONFIDENTIAL

This document gives preliminary information on the apparatus and materials required for the AS Practical Assessment.

Information about the apparatus and materials required for this assessment must NOT be communicated to students. If apparatus/materials have their serial code and/or manufacturer specified then it is essential that centres use this exact apparatus/material.

On receipt of this APPARATUS AND MATERIALS LIST, centres must contact Gavin Gray, ggray@ccea.org.uk immediately if they have difficulty in sourcing the specified apparatus or materials.

Teachers will be given detailed instructions for setting up the experiment in the *Confidential Instructions for Physics (Advanced Subsidiary) Practical Test*, to which they will have confidential access from April 2024.

Teachers will have confidential access to a copy of the experimental test two working days (48 hours) before the start of the assessment.

The AS 3 Practical Techniques Assessment is a test of practical skills consisting of 4 short experimental tests (40 marks). The duration of the assessment is 1 hour.

The apparatus in the following list will allow for **one experiment** to be set up for the practical test which makes up questions 1–4. In other words, each set of apparatus (as listed on **pages 4 and 5**) will accommodate four candidates when doing the circus of experiments.

The apparatus can be used for alternative sessions according to the following schedule:

Tuesday 7th May Physics AS 3A (SPH31)

(Main Session) **9.15 am–10.15 am**

(First Alternative) **10.30 am–11.30 am**

(Second Alternative) **11.45 am–12.45 pm**

(Third Alternative) **1.15 pm–2.15 pm**

(Fourth Alternative) **2.30 pm–3.30 pm**

One set of apparatus for AS 3A (SPH31) will therefore be sufficient for twenty candidates on **Tuesday 7th May** if the Main Session and all four alternatives are used. A laboratory may contain one, two, three or more sets of apparatus. This means that four, eight, twelve or more candidates can be accommodated in the same session. **To maintain the confidentiality of details of the practical tests, candidates entered for any of the alternative sessions must be segregated within the centre so that there can be no communication with candidates who have taken an earlier test in any centre.**

IMPORTANT NOTICE

Centres are urged to order items needed for the Physics Practical Tests from the suppliers as soon as possible.

Question 1

Requirements

- 1 × retort stand and clamp
- 1 × large rubber bung
- 3 × different tuning forks between 300 and 520 Hz
- 1 × resonance tube (plastic pipe cut to 35 cm in length and not wider than the measuring cylinder)
- 1 × measuring cylinder (approximately 30 cm high to accommodate the plastic pipe)
- 1 × half metre rule
- 3 × sticky labels

Question 2

Requirements

- 2 × wooden metre rules
- 1 × 50 ml glass beaker
- 1 × stop clock accurate to 0.01 s
- Blu Tack

Question 3

Requirements

- 1 × A4 sheet of 400 gsm cardboard (0.41 mm thick)
- 1 × 30 cm ruler
- 1 × vernier caliper (analogue or digital)
- 1 × micrometer screw gauge (analogue or digital)
- 1 × top pan balance accurate to 1 dp
- 1 × 2p coin
- paper glue, such as Pritt-stick

Question 4

Requirements

- 10 × connecting leads
- 1 × digital voltmeter (0–20V) reading to 0.01 V
- 1 × digital ohmmeter reading to 1 Ω capable of measuring up to 150 Ω
- 2 × 1.5 V D cells
- 2 × battery holders
- 1 × push switch
- 1 × 33 Ω
- 1 × 100 Ω
- 2 × component holders
- 4 × sticky labels



Rewarding Learning

**ADVANCED SUBSIDIARY (AS)
General Certificate of Education
2024**

Physics

Assessment Unit AS 3A

Practical Techniques and Data Analysis

[SPH31]

TUESDAY 7 MAY, MORNING

CONFIDENTIAL INSTRUCTIONS

1 Confidential Instructions

These instructions will give detailed guidance on setting up and testing the apparatus and materials to be used. **Again, information contained within the Confidential Instructions must not be relayed to candidates under any circumstances.** If at this point, centres find that the testing process produces results different to those specified in the Confidential Instructions, they must contact the CCEA Science Subject Officer (ggray@ccea.org.uk) immediately.

2 Final Apparatus Testing

The practical assessment question paper will be made available to the Head of Physics **two** working days before the timetabled starting time so that teachers and technicians can carry out a final test on the experiments. If on checking the apparatus gives unexpected results, the CCEA Physics Subject Officer should be contacted immediately (ggray@ccea.org.uk). If the problem cannot be resolved, then the centre must e-mail the CCEA Physics Subject Officer stating the centre name and number, the specific nature of the problem and the range of anomalous results produced. CCEA will respond by acknowledging receipt of the e-mail. If you do not receive a response within 24 hours, please contact the CCEA Physics Subject Officer by telephone (028 90261200 Ext 2270) to confirm that CCEA has received your e-mail.

3 Practical Assessment AS 3A

The AS 3A Practical Techniques Assessment is a test of practical skills comprised of 4 short experimental tests. The duration of the assessment is 1 hour. Some of this time will be set aside for supervisors to re-set the apparatus ready for the next candidates. The assessment should be run as a circus of experiments with candidates moving to the next experiment at the designated time. Candidates should work individually and there should be no communication between candidates at any point during the assessment. The assessment should be timed as follows:

Questions	Time
Q1 (Short practical test)	12 minutes
Changeover and practical write-up	2 minutes
Q2 (Short practical test)	12 minutes
Changeover and practical write-up	2 minutes
Q3 (Short practical test)	12 minutes
Changeover and practical write-up	2 minutes
Q4 (Short practical test)	12 minutes
Changeover and practical write-up	2 minutes
End of test write-up	4 minutes

At the end of each 12 minute period, candidates must stop using the apparatus. During each 2 minute changeover period candidates may write up anything they have not completed however they will not have access to the apparatus.

At the end of the test a 4 minute period is provided for candidates to complete their answer to any question, however they will not have access to the apparatus.

4 After the Practical Assessments

When the individual exam sessions have finished, please return the AS 3A practical scripts together with the corresponding advice notes to the examinations officer (EO). We will collect these by the day after the examination. If we don't, please contact us immediately to arrange another time for collection.

Where the centre finds that a candidate may have been disadvantaged because the apparatus did not function as intended, the supervising teachers should make a report to the EO. The EO will forward the confidential report on the issue and the candidates affected to the centre support section at CCEA for special consideration. Candidates should be identified by their examination number.

IMPORTANT NOTICE

Centres are urged to order items needed for the Physics Practical Tests from the suppliers as soon as possible.

Question 1

Requirements

- 1 × retort stand and clamp
- 1 × large rubber bung
- 3 × different tuning forks between 300 and 520 Hz
- 1 × resonance tube (plastic pipe cut to 35 cm in length and not wider than the measuring cylinder)
- 1 × measuring cylinder (approximately 30 cm high to accommodate the plastic pipe)
- 1 × half metre rule
- sticky labels

Preparation

Label each tuning fork with its frequency to the nearest whole number.

Nearly fill the measuring cylinder with water. Place the resonance tube in the water.

Place the clamp loosely around the resonance tube as it rests on the bottom of the measuring cylinder.

Place the three tuning forks, rubber bung and the half metre rule beside the measuring cylinder.

Action at changeover

Ensure the resonance tube rests on the bottom of the measuring cylinder with the clamp loosely placed around it.

Ensure the three tuning forks, rubber bung and the half metre rule are placed beside the measuring cylinder.

Question 2

Requirements

- 2 × wooden metre rules
- 1 × 50 ml beaker
- 1 × stop clock accurate to 0.01 s
- Blu Tack

Preparation

Cut one of the metre rules to make the following two laths:

- 1 × 40 cm
- 1 × 60 cm

Use Blu Tack to secure the 50 ml beaker to the bench as shown below.
Balance the 40 cm lath on the beaker.
Place the 60 cm lath on the bench beside the beaker.
Place the other metre rule and stop clock on the bench.

Action at change over

Zero the stop clock.

Balance the 40 cm lath on top of the beaker.

Place the 60 cm lath, metre rule and stop clock on the bench.

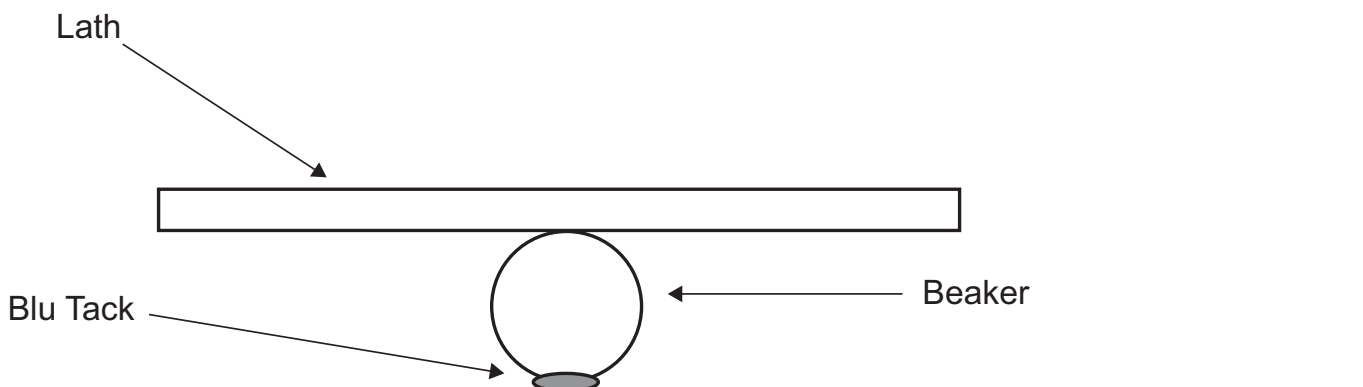

Question 3

Requirements

- 1 × A4 sheet of 400 gsm cardboard (0.41 mm thick) [A4 or larger]
- 1 × 30 cm ruler
- 1 × vernier caliper (analogue or digital)
- 1 × micrometer screw gauge (analogue or digital)
- 1 × top pan balance accurate to 1 dp
- 1 × 2p coin
- paper glue, such as Pritt-stick

Preparation

Fold the A4 card in half and cut to create 2 × A5 cards.

Glue the two pieces of card together (to make double thickness)

Using a Stanley knife, cut a regular hexagon of side 48 mm

Place the 2p coin approximately in the centre of the hexagon, draw around it and cut out the circular hole.

Place the micrometer screw gauge, ruler and vernier caliper beside the hexagon.

Turn on the top pan balance and ensure the reading is 0.0g. Place it beside the hexagon.

Action at changeover

Place the micrometer screw gauge, ruler and vernier caliper beside the hexagon.

Turn on the top pan balance and ensure the reading is 0.0g. Place it beside the hexagon.

Question 4

Requirements

- 10 × connecting leads
- 1 × digital voltmeter (0-20V) reading to 0.01 V
- 1 × digital ohmmeter reading to 1 Ω capable of measuring up to 150 Ω
- 2 × 1.5 V D cells
- 2 × battery holders
- 1 × push switch
- 1 × 33 Ω
- 1 × 100 Ω
- 2 × component holders
- sticky labels

Preparation

Label the voltmeter V

Label the ohmmeter Ω

Place the $33\ \Omega$ and $100\ \Omega$ resistors in separate component holders and ensure the markings on the resistors are completely covered. Label the $33\ \Omega$ resistor X and the $100\ \Omega$ resistor Y.

Set up the two cells in series with a digital voltmeter across the cells.

Place resistor X and the push switch in a circuit as shown in Fig. 4.1

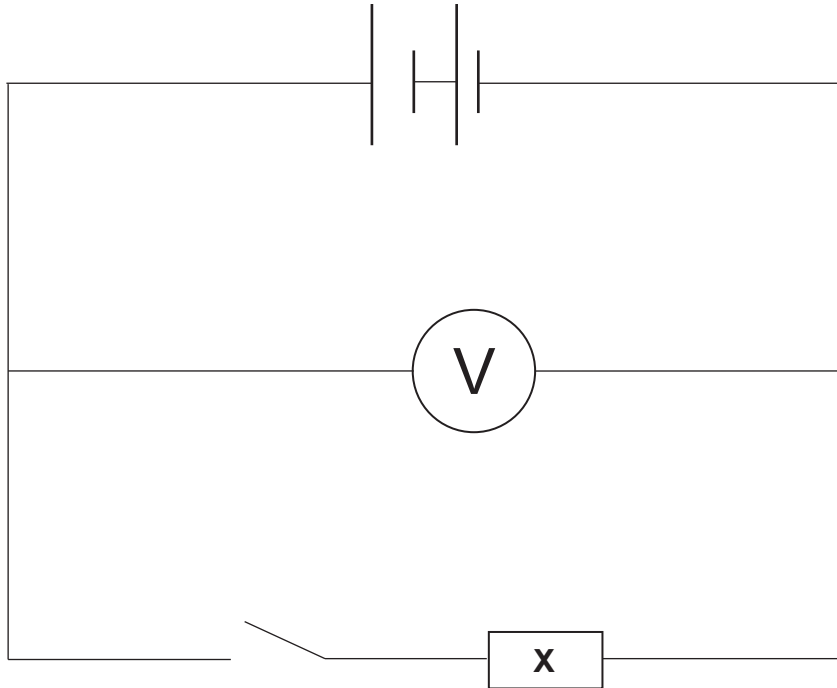

Fig. 4.1

Set the voltmeter to read up to 20 V dc.

Place connecting wires in the terminals of the digital ohmmeter.

Switch on the ohmmeter and set it to a setting that will measure the resistance of each resistor to the nearest ohm.

Place resistor Y on the bench beside the circuit.

Action at changeover

Ensure the circuit is returned to the original arrangement as in Fig. 4.1

Place resistor Y and the ohmmeter on the bench beside the circuit.

Check the setting on the ohmmeter.

