



Rewarding Learning

ADVANCED SUBSIDIARY (AS)
General Certificate of Education
2023

Centre Number

--	--	--	--	--

Candidate Number

--	--	--	--

Physics

Assessment Unit AS 3A

assessing

Practical Techniques
and Data Analysis



SPH31

[SPH31]

WEDNESDAY 10 MAY, MORNING

TIME

1 hour.

INSTRUCTIONS TO CANDIDATES

Write your Centre Number and Candidate Number in the spaces provided at the top of this page.

Answer **all** the questions in this booklet. Rough work and calculations must also be done in this booklet. Except where instructed, do **not** describe the apparatus or experimental procedures. The Teacher/Supervisor will tell you the order in which you are to answer the questions. One hour is to be spent on four short experimental tests.

After 12 minutes you must stop using the apparatus so that it can be rearranged for the next candidate. At 14 minutes you will be instructed to move to the station for the next question.

At the end of the test a 4 minute period will be provided for you to complete your answer to any question, but you will not have access to the apparatus during this time.

INFORMATION FOR CANDIDATES

The total mark for this paper is 40.

Figures in brackets printed down the right-hand side of pages indicate the marks awarded to each question or part question.

You may use an electronic calculator.

For Examiner's
use only

Question Number	Marks	Remark
1		
2		
3		
4		

Total Marks		
-------------	--	--

1 Identify the contents of three boxes.

There are three boxes labelled X, Y and Z on the desk. Each box contains a wire made from the same material but with different dimensions.

The boxes contain the following:

- a wire of length L and cross-section area A
- a wire of length $2L$ and cross-section area A
- a wire of length L and cross-section area $2A$

(a) Set up a suitable circuit using the equipment provided to allow you to calculate the resistance of each box.

In **Table 1.1**, record all your results and the calculated value of the resistance for each box. Head the columns appropriately and include the correct unit for each quantity.

Table 1.1

Box X			
Box Y			
Box Z			

[7]

Examiner Only	
Marks	Remark

- (b) Use your results in **Table 1.1** to identify the contents of each box. In **Table 1.2**, write down the letter of the box containing each wire.

Explain how you arrived at your answers.

Table 1.2

	Box
A wire of length L and cross-section area A	
A wire of length $2L$ and cross-section area A	
A wire of length L and cross-section area $2A$	

Explanation:

[3]

Examiner Only	
Marks	Remark

2 Use the apparatus to determine the mass of a bag of sand.

The apparatus in **Fig. 2.1** has been set up for you. String, with two newtonmeters connected to it, is passed over two fixed pulleys and a mass is suspended from each end of the string. The masses are equal in magnitude. The newtonmeters measure the tension in two parts of the string. There is a loop at the centre of the string between the newtonmeters.

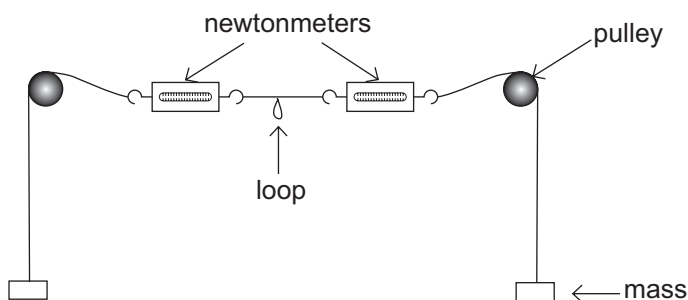

Fig. 2.1

(a) Gently hang the bag of sand from the loop on the string.

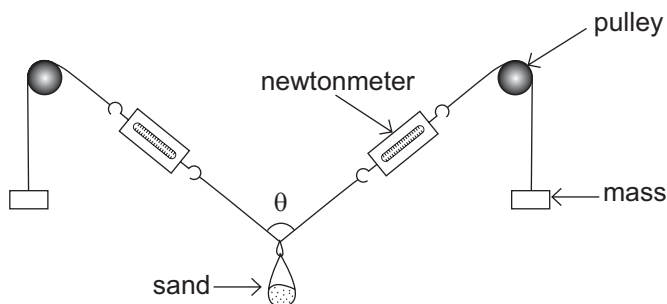

Fig. 2.2

(i) Measure the angle θ between the strings, as shown in **Fig. 2.2**.

Angle $\theta = \text{_____}^\circ$ [1]

(ii) State the uncertainty in the protractor used to measure θ .

Uncertainty = _____° [1]

Examiner Only	
Marks	Remark

- (iii) Calculate the average tension in the string by taking readings from both newtonmeters.

Newtonmeter readings: _____ N and _____ N

Average tension = _____ N [2]

- (b) There are two 50 g masses on the desk. Add one 50 g mass onto each mass hanger.

- (i) Measure the new angle θ .

Angle θ = _____° [1]

- (ii) Calculate the average tension in the string by taking readings from both newtonmeters.

Newtonmeter readings: _____ N and _____ N

Average tension = _____ N [1]

- (c) Using your answers to both (a) and (b), calculate a value for the mass of the bag of sand (including the hook).

Begin your calculations by finding the vertical component of the tension in the string.

Give your answer in grams.

Mass of the bag of sand = _____ g [4]

Examiner Only

Marks Remark

3 Investigate the relationship between the height from which a marble is dropped and the diameter of the crater that is formed when the marble hits the surface of a tray of sugar.

The apparatus shown in **Fig. 3.1** has been set up for you. The 0 cm end of the metre rule is at the surface of the sugar.

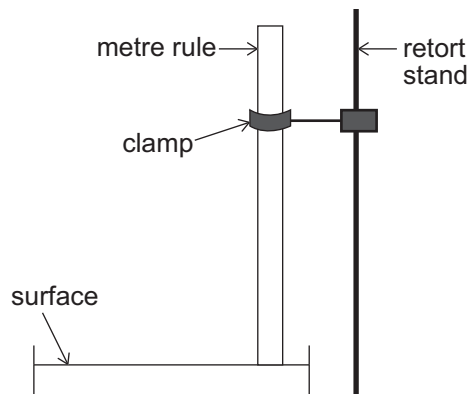

Fig. 3.1

When the marble is dropped from a height h above the surface, a crater will be formed when it hits the sugar. Some of the sugar will be dislodged and form a raised ring as shown in **Fig. 3.2**. The diameter d of the raised ring is to be measured.

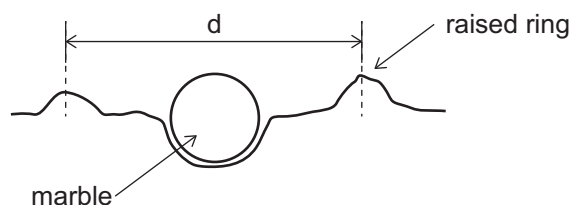

Fig. 3.2

- (a)** Drop the marble from a height h of 20 cm. Use the vernier calipers to measure the diameter d of the crater. Repeat the measurement across a second diameter.

Remove the marble and flatten the surface of the sugar with the edge of the ruler.

Repeat the drop at $h = 20$ cm and obtain two more values of d .

Repeat this procedure from a new drop height $h = 70$ cm.

- (i)** Record all your results in **Table 3.1**.

Examiner Only	
Marks	Remark

Table 3.1

h / cm	First drop		Second drop		Average d / cm
	d ₁ / cm	d ₂ / cm	d ₁ / cm	d ₂ / cm	
20					
70					

[6]

(ii) Explain why the diameter should be measured in two different places for each drop height.

[1]

(b) One theory suggests that h is proportional to d⁴.

Use your results in **Table 3.1** to test this theory mathematically. Show all your working out.

Conclusion:

[3]

Examiner Only	
Marks	Remark

4 Determine a value for the specific heat capacity of water.

The specific heat capacity of water is the amount of energy needed to raise the temperature of 1 g of water by 1 °C.

You have been supplied with a beaker of ice, some warm water in a beaker and a third empty beaker. The beakers are identical.

- (a)** Use the scales to take measurements to allow you to determine the mass of the ice m_i and the mass of the water m_w .

$$m_i = \text{_____ g}$$

$$m_w = \text{_____ g} \quad [3]$$

- (b) (i)** Use the thermometer provided to measure the temperature T_1 of the warm water.

$$T_1 = \text{_____ } ^\circ\text{C}$$

Add the water to the ice and measure the temperature T_2 of the mixture when all of the ice has melted.

$$T_2 = \text{_____ } ^\circ\text{C}$$

State the uncertainty in the values of temperature recorded.

$$\text{Uncertainty} = \text{_____ } ^\circ\text{C} \quad [3]$$

- (ii)** Calculate the change in temperature ΔT and state the uncertainty in the value.

$$\Delta T = \text{_____ } ^\circ\text{C}$$

$$\text{Uncertainty} = \text{_____ } ^\circ\text{C} \quad [2]$$

Examiner Only

Marks Remark

The specific heat capacity c of water is given by **Equation 4.1**.

$$c = \frac{334 m_i}{\Delta T m_w - T_2 m_i} \quad \text{Equation 4.1}$$

(c) Use your answers to parts (a) and (b) to calculate a value for c .

$$c = \text{_____ } \text{Jg}^{-1}\text{C}^{-1}$$

[2]

THIS IS THE END OF THE QUESTION PAPER

Examiner Only

Marks

Remark

Permission to reproduce all copyright material has been applied for.
In some cases, efforts to contact copyright holders may have been unsuccessful and CCEA
will be happy to rectify any omissions of acknowledgement in future if notified.



Rewarding Learning

**ADVANCED SUBSIDIARY (AS)
General Certificate of Education
2023**

Physics

Assessment Unit AS 3A

Practical Techniques and Data Analysis

[SPH31]

WEDNESDAY 10 MAY, MORNING

APPARATUS AND MATERIALS LIST

PHYSICS UNIT 3 (AS 3A)
APPARATUS AND MATERIALS REQUIRED FOR PRACTICAL ASSESSMENT

CONFIDENTIAL

This document gives preliminary information on the apparatus and materials required for the AS Practical Assessment.

Information about the apparatus and materials required for this assessment must NOT be communicated to students. If apparatus/materials have their serial code and/or manufacturer specified then it is essential that centres use this exact apparatus/material.

On receipt of this APPARATUS AND MATERIALS LIST, centres must contact Gavin Gray, ggray@ccea.org.uk immediately if they have difficulty in sourcing the specified apparatus or materials.

Teachers will be given detailed instructions for setting up the experiment in the *Confidential Instructions for Physics (Advanced Subsidiary) Practical Test*, to which they will have confidential access from April 2023.

Teachers will have confidential access to a copy of the experimental test two working days (48 hours) before the start of the assessment.

The AS 3 Practical Techniques Assessment is a test of practical skills consisting of 4 short experimental tests (40 marks). The duration of the assessment is 1 hour.

The apparatus in the following list will allow for **one experiment** to be set up for the practical test which makes up questions 1–4. In other words, each set of apparatus (as listed on **pages 4 and 5**) will accommodate four candidates when doing the circus of experiments.

The apparatus can be used for alternative sessions according to the following schedule:

Wednesday 10 May, 2023 Physics AS 3A (SPH31)

(Main Session) **9.15 am–10.15 am**

(First Alternative) **10.30 am–11.30 am**

(Second Alternative) **11.45 am–12.45 pm**

(Third Alternative) **1.15 pm–2.15 pm**

(Fourth Alternative) **2.30 pm–3.30 pm**

One set of apparatus for AS 3A (SPH31) will therefore be sufficient for twenty candidates on **Wednesday 10 May** if the Main Session and all four alternatives are used. A laboratory may contain one, two, three or more sets of apparatus. This means that four, eight, twelve or more candidates can be accommodated in the same session. **To maintain the confidentiality of details of the practical tests, candidates entered for any of the alternative sessions must be segregated within the centre so that there can be no communication with candidates who have taken an earlier test in any centre.**

IMPORTANT NOTICE

Centres are urged to order items needed for the Physics Practical Tests from the suppliers as soon as possible.

Question 1

Requirements

- 22 Ω resistor \times 5
- Component holder \times 3
- Opaque box to hold component holder \times 3
- Connecting leads \times 10
- Milliammeter to read up to 200 mA to 0.1 mA
- Voltmeter to read to 0.01 V
- 1.5 V cell in holder
- Switch

Question 2

Requirements

- Newtonmeter 0–10 N to 0.1 N \times 2
- Pulley to be hung from or clamped to retort stand \times 2
- Retort stand, 75 cm tall \times 2
- G clamp \times 2
- String
- 100 g mass hanger \times 2
- 50 g masses \times 4
- Sand
- Small plastic bag such as a food storage bag
- Paperclip
- Protractor to 1°

Question 3

Requirements

- Retort stand, boss head and clamp
- Granulated sugar
- Plastic tray, dimensions approx. 20 cm × 15 cm, depth 3–5 cm
- Metre rule
- Marble, approx 1.5 cm diameter
- Vernier caliper
- 30 cm ruler

Question 4

Requirements

- Ice, roughly crushed
- Water
- 250 ml beaker × 3
- Electronic scales to measure up to 200g to 0.1 g
- Thermometer
- Kettle (1 per room)



Rewarding Learning

**ADVANCED SUBSIDIARY (AS)
General Certificate of Education
2023**

Physics

Assessment Unit AS 3A

Practical Techniques and Data Analysis

[SPH31]

WEDNESDAY 10 MAY, MORNING

CONFIDENTIAL INSTRUCTIONS

1 Confidential Instructions

These instructions will give detailed guidance on setting up and testing the apparatus and materials to be used. **Again, information contained within the Confidential Instructions must not be relayed to candidates under any circumstances.** If at this point, centres find that the testing process produces results different to those specified in the Confidential Instructions, they must contact the CCEA Science Subject Officer (ggray@ccea.org.uk) immediately.

2 Final Apparatus Testing

The practical assessment question paper will be made available to the Head of Physics **two** working days before the timetabled starting time so that teachers and technicians can carry out a final test on the experiments. If on checking the apparatus gives unexpected results, the CCEA Physics Subject Officer should be contacted immediately (ggray@ccea.org.uk). If the problem cannot be resolved, then the centre must e-mail the CCEA Physics Subject Officer stating the centre name and number, the specific nature of the problem and the range of anomalous results produced. CCEA will respond by acknowledging receipt of the e-mail. If you do not receive a response within 24 hours, please contact the CCEA Physics Subject Officer by telephone (028 90261200 Ext 2270) to confirm that CCEA has received your e-mail.

3 Practical Assessment AS 3A

The AS 3A Practical Techniques Assessment is a test of practical skills comprised of 4 short experimental tests. The duration of the assessment is 1 hour. Some of this time will be set aside for supervisors to re-set the apparatus ready for the next candidates. The assessment should be run as a circus of experiments with candidates moving to the next experiment at the designated time. The assessment should be timed as follows:

Questions	Time
Q1 (Short practical test)	12 minutes
Changeover and practical write-up	2 minutes
Q2 (Short practical test)	12 minutes
Changeover and practical write-up	2 minutes
Q3 (Short practical test)	12 minutes
Changeover and practical write-up	2 minutes
Q4 (Short practical test)	12 minutes
Changeover and practical write-up	2 minutes
End of test write-up	4 minutes

At the end of each 12 minute period, candidates must stop using the apparatus. During each 2 minute changeover period candidates may write up anything they have not completed however they will not have access to the apparatus.

At the end of the test a 4 minute period is provided for candidates to complete their answer to any question, however they will not have access to the apparatus.

4 After the Practical Assessments

When the individual exam sessions have finished, please return the AS 3A practical scripts together with the corresponding advice notes to the examinations officer (EO). We will collect these by the day after the examination. If we don't, please contact us immediately to arrange another time for collection.

Where the centre finds that a candidate may have been disadvantaged because the apparatus did not function as intended, the supervising teachers should make a report to the EO. The EO will forward the confidential report on the issue and the candidates affected to the centre support section at CCEA for special consideration. Candidates should be identified by their examination number.

IMPORTANT NOTICE

Centres are urged to order items needed for the Physics Practical Tests from the suppliers as soon as possible.

Question 1

Requirements

- 22 Ω resistor \times 5
- Component holder \times 3
- Opaque box to hold component holder \times 3
- Connecting leads \times 10
- Milliammeter to read up to 200 mA to 0.1 mA
- Voltmeter to read to 0.01 V
- 1.5 V cell in holder
- Switch

Preparation

Place one of the resistors into a component holder.

Connect two of the remaining resistors in series and place in a component holder.

Connect the remaining two resistors in parallel and place in a component holder.

Add a connecting lead to each end of the three component holders.

Place each component holder into an opaque box with the end of the connecting leads exposed to enable connection to another component in a circuit.

Label the box containing the resistors in parallel 'X', the box containing the single resistor 'Y' and the box containing the resistors in series 'Z'.

Before the examination

Set all the apparatus on the desk separately.

Set the voltmeter and ammeter to the correct settings and turn them on.

Action at changeover

Return the apparatus to the original arrangement on the desk. Check the settings on the meters and their batteries.

Question 2

Requirements

- Newtonmeter 0–10 N to 0.1 N × 2
- Pulley to be hung from or clamped to retort stand × 2
- Retort stand, 75 cm tall × 2
- G-clamp × 2
- String
- 100 g mass hanger × 2
- 50 g masses × 4
- Sand
- Small plastic bag such as a food storage bag
- Paperclip
- Protractor to 1°

Preparation

Fill the plastic bag with approximately 120 g of sand. Tie a knot in the top of the bag. Open the paperclip out and hook one end through the knot, leaving the other end to act as a hanger as shown in **Fig 2.1**.



Fig 2.1

Place a 50 g mass on each mass hanger.

Before the examination

Clamp a pulley close to the top of each retort stand ensuring that both pulleys are at the same height.

Use the G-clamps to clamp the retort stands to the desk.

Use the string and newtonmeters to set up the arrangement shown in **Fig 2.2**.

Tie either end of a string (approx length 6 cm) to the hooks of the newtonmeters. Attach a small loop to the centre of this string.

From the other end of each newtonmeter tie a string that will pass over the pulley and attach to a mass hanger with a 50 g mass added.



Fig. 2.2

Check that, when the bag of sand is hung from the loop, the bag does not touch the bench and the mass hangers do not hit the pulleys, as shown in **Fig. 2.3**



Fig. 2.3

When a spare 50 g mass is added to each hanger, check that the newtonmeters do not hit the pulleys, as shown in **Fig. 2.4**

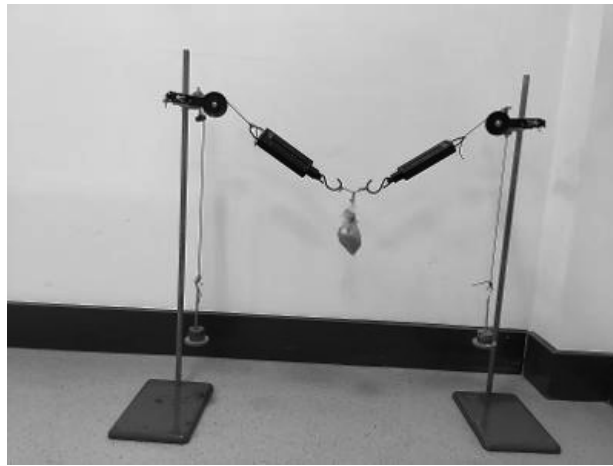

Fig 2.4

Action at changeover

Remove the two spare 50 g masses and the bag of sand and set them close to the apparatus. Set the protractor close to the apparatus so returning the apparatus to its original arrangement (as in Fig 2.2).

Question 3

Requirements

- Retort stand, boss head and clamp
- Granulated sugar
- Plastic tray, dimensions approx. 20 cm × 15 cm, depth 3–5 cm
- Metre rule
- Marble, approx 1.5 cm diameter
- Vernier caliper
- 30 cm ruler

Preparation

Fill the tray with the sugar so that the surface of the sugar is approx. 0.5 cm below the edge of the tray.

Before the examination

Clamp the metre rule into the retort stand and set the zero of the metre rule at the surface level of the sugar as shown in **Fig 3.1**.

Check that the surface of the sugar is flat.

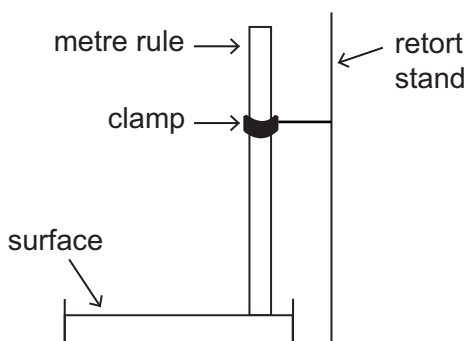

Fig 3.1

Place the marble and the 30 cm ruler close to the apparatus.

Action at changeover

Return the apparatus to its original arrangement on the desk. Smooth the surface of the sugar.

Question 4

Requirements

- Ice, roughly crushed
- Water
- 250 ml beaker × 3
- Electronic scales to measure up to 200g to 0.1 g
- Thermometer
- Kettle (1 per room)

Before the examination

Boil the water and pour approx. 70 ml of water into one of the beakers. When the candidate begins the experiment, the water should have cooled to a temp of approx. 70 °C.

Place approx 40g of ice into a second beaker.

Leave the remaining beaker, the scales and the thermometer on the desk.

Action at changeover

Replace the beakers, with ice and water in two and an empty beaker on the desk.

Return the scales to zero.

Place the thermometer on the desk.

